

STEAM TRAPS

WT3000

Thermostatic Steam Trap (Repairable)

Watson McDaniel reserves the right to change the designs and/or materials of its products without notice.
©2004 Watson McDaniel Company

Revised 9/2004

Model	WT3000
Sizes	1/2", 3/4"
Connections	NPT, SW, FLG
Body Material	Stainless Steel
Options	Strainer, Blowdown Valve
PMO Max. Operating Pressure	650 PSIG
TMO Max. Operating Temperature	Saturated Steam Temp.
PMA Max. Allowable Pressure	906 PSIG @ 100°F
TMA Max. Allowable Temperature	750°F @ 725 PSIG



TYPICAL APPLICATIONS

PROCESS: The WT3000 thermostatic steam trap is used for industrial process applications. Their compact size, all stainless steel construction, excellent air handling capability and wide operating pressure range make them a great choice for most process applications. Thermostatic traps are far superior to bucket traps and thermodynamic disc traps in their ability to remove air from the system.

HOW IT WORKS

The thermostatic trap contains a welded stainless steel thermal element that expands when heated and contracts when cooled. When air and condensate are present, the trap is in the open discharge position. When steam reaches the trap, the element expands and closes off tightly.

FEATURES

- The thermal element and seat can be easily removed and replaced in minutes with the trap body still in-line
- Operates at steam pressures up to 650 PSIG
- Thermostatic traps have excellent air handling capability allowing air to be discharged rapidly and steam to enter the system quickly during start up
- Welded stainless steel thermal element that resists shock from water hammer
- Freezeproof when the trap is installed in a vertical orientation allowing for complete condensate drainage
- Body is produced from stainless steel investment casting
- Hardened stainless steel seat for extended service life
- Available with integral strainer and blowdown

SAMPLE SPECIFICATION

The steam trap shall be of a thermostatic type with stainless steel body, stainless steel thermal element and internal strainer. Trap must be in-line repairable with a bolt on type cover that is sealed with a spiral wound Stainless Steel AISI 316 gasket. Seat and disc to be hardened stainless steel.

INSTALLATION

Isolation valves should be installed with trap. Trap can be installed in any position.

MAINTENANCE

If the trap fails, remove the cover and replace the internal working components. Repair kit includes thermal element, seat and gasket. For full maintenance details see Installation and Maintenance Manual.

OPTIONS

Strainer, blowdown valve, and steam lock release.

S = Strainer

SB = Strainer and blowdown valve

Special bellows available upon request.

MATERIALS

Cover & Body	Stainless Steel, AISI 316L
Thermal Element	Stainless Steel, AISI 300
Valve & Seat	Stainless Steel, AISI 416
Cover Gasket	Stainless Steel, AISI 316
Seat Gasket	Stainless Steel, AISI 316
Cover Bolts	Steel, ASTM A193 GR B7 Nickel Plated
Screen*	0.046 Perforated Stainless Steel AISI 304
Blowdown Valve*	Stainless Steel AISI 303

*Screen and blowdown valve are optional

HOW TO ORDER

Refer to the capacity chart to determine which model is required to satisfy the condensate load.

Add **S** to the end of the model code if a strainer is required.

Add **B** to the end of the model code if a blowdown valve is required.

5/16" orifice is standard and will be supplied if not specified. Specify orifice size 3/16" or 5/16".

Example:

1/2" WT3000S 5/16" orifice 1/2" connection with strainer
3/4" WT3000SB 3/16" orifice 3/4" connections with strainer and blowdown valve

WT3000

Thermostatic Steam Trap

Revised 9/2004

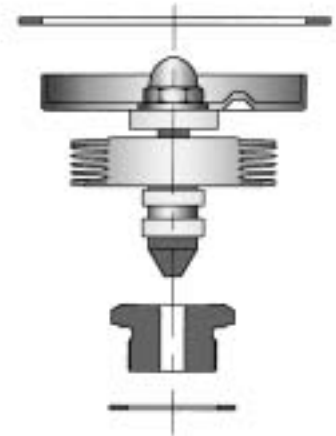
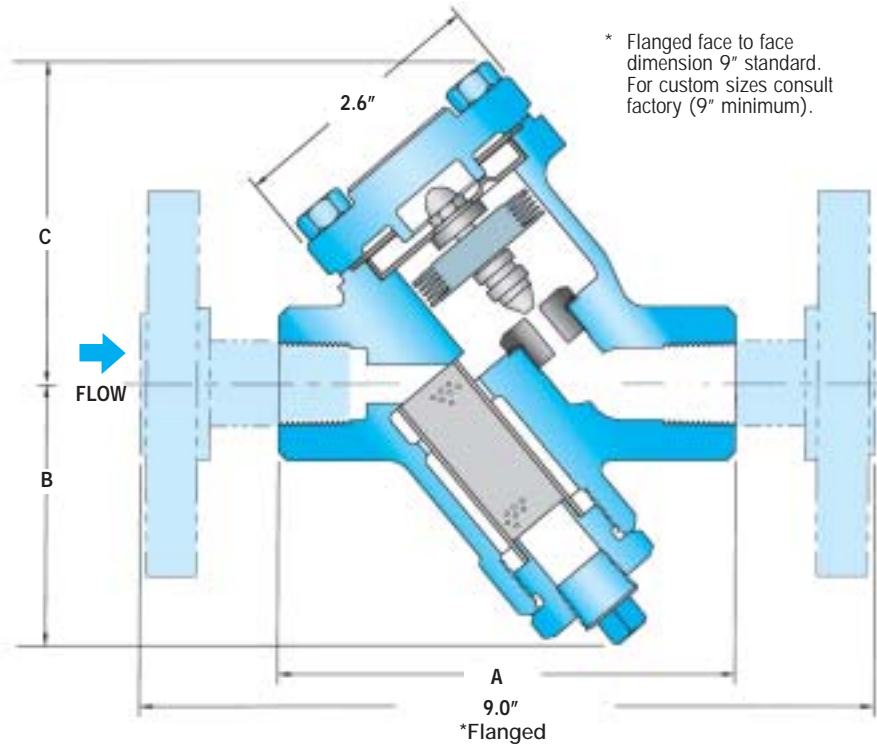

Internals

DIMENSIONS & WEIGHTS – inches/pounds

Size/Model	Connection	A	B	C	Weight (lbs)
Series WT3000, WT3000S					
1/2"	NPT, SW	4.5	2.57	3.13	4.5
3/4"	NPT, SW	4.5	2.57	3.13	4.5
Series WT3000SB (Strainer & Blowdown Valve)					
1/2"	NPT, SW	4.5	3.2	3.13	4.5
3/4"	NPT, SW	4.5	3.2	3.13	4.5

S = Strainer only

SB = Strainer and Blowdown

CAPACITIES – Condensate (lbs/hr)

Model	Pipe Size	Orifice Size	Steam Inlet Pressure (PSIG)															
			5	10	20	50	100	125	150	200	250	300	350	400	450	500	600	650
WT3000	1/2", 3/4"	3/16"	441	625	882	1391	1827	1969	2095	2305	2483	2636	2777	2903	3019	3129	3323	3413
WT3000S		5/16"	903	1271	1811	2861	3754	4043	4300	4730	5093	5413	5702	5959	6195	6421	6820	7004
WT3000SB																		

Back Pressure as Percentage of Inlet Pressure	10	20	25	30	40	50	60	70	80	90
Percentage Decrease in Trap Capacity	0	0	0	2	5	12	20	30	40	55

Notes: 5/16" orifice size is standard and is normally used on process equipment.

3/16" orifice size is offered for reduced capacity.

5/64" low capacity orifice is available upon request.