

WT2500

Thermostatic Steam Trap

Revised 9/2004

Model	WT2500
Sizes	1/2", 3/4"
Connections	NPT
Body Material	Cast iron
PMO Max. Operating Pressure	250 PSIG
TMO Max. Operating Temperature	406°F
PMA Max. Allowable Pressure	250 PSIG up to 450°F
TMA Max. Allowable Temperature	450°F @ 250 PSIG

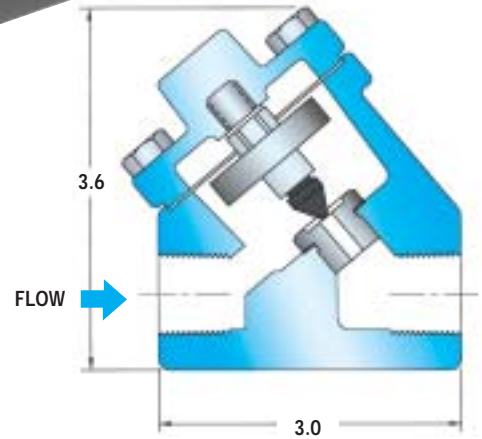

TYPICAL APPLICATIONS

DRIP, TRACER, PROCESS: The WT2500 thermostatic steam trap is used for drip, tracing and process applications. Their compact size, excellent air handling capability and wide operating pressure range make them a great choice for most applications. Thermostatic traps are far superior to bucket traps and thermodynamic disc traps in their ability to remove air from the system.

HOW IT WORKS

The thermostatic trap contains a welded stainless steel thermal element that expands when heated and contracts when cooled. When air and condensate are present, the trap is in the open discharge position. When steam reaches the trap, the element expands and closes off tightly.

FEATURES

- The thermal element and seat can be easily removed and replaced in minutes with the trap body still in-line
- Operates at steam pressures up to 250 PSIG
- Thermostatic traps have excellent air handling capability allowing air to be discharged rapidly and steam to enter the system quickly during start up
- Welded stainless steel thermal element that resists shock from water hammer
- Freezeproof when the trap is installed in a vertical orientation allowing for complete condensate drainage
- Hardened stainless steel seat for extended service life

MATERIALS

Cover & Body	Cast Iron ASTM A-126 Class B
Thermal Element	Stainless Steel, AISI 302
Valve & Seat	Stainless Steel, AISI 416
Cover Gasket	Garlock

CAPACITIES – condensate (lbs/hr)

Model	Orifice Size	Steam Inlet Pressure (PSIG)								
		5	10	20	50	100	125	150	200	250
WT2500	3/16"	441	625	882	1391	1827	1969	2095	2305	2483
WT2500	5/16"	903	1271	1811	2861	3754	4043	4300	4730	5093

Note: 5/64" low capacity orifice is available upon request.

SAMPLE SPECIFICATION

The steam trap shall be of a thermostatic type with cast iron body and stainless steel thermal element. Trap must be in-line repairable with a bolt on type cover that is sealed with a spiral wound Stainless Steel AISI 316 gasket. Seat and disc to be hardened stainless steel.

MAINTENANCE & INSTALLATION

Trap can be installed in any position. If replacement is required, remove the cover and replace the internal working components. Repair kit includes thermal element, seat and gasket. For full maintenance details see Installation and Maintenance Manual.

OPTION

Special bellows available upon request.

HOW TO ORDER

Refer to the capacity chart to determine which model is required to satisfy the condensate load.

5/16" orifice is standard and will be supplied if not specified. Specify orifice size 3/16" or 5/16".

Example: 1/2" WT2500 5/16" orifice 1/2" connection