

STEAM TRAPS

WD700S

Thermodynamic Steam Trap (Repairable)

Watson McDaniel reserves the right to change the designs and/or materials of its products without notice.
©2004 Watson McDaniel Company

Revised 9/2004

Model	WD700S, WD700HS
Sizes	1/2", 3/4", 1"
Connections	NPT, SW, FLG
Body Material	Chrome-Moly Alloy Steel
Options	Blowdown Valve, Insulation Cap
PMO Max. Operating Pressure	600 PSIG
TMO Max. Operating Temperature	800°F
PMA Max. Allowable Pressure	600 PSIG up to 800°F
TMA Max. Allowable Temperature	800°F @ 600 PSIG

WD700S is a Direct Replacement for Yarway Model 721



WD700S
Strainer



WD700SB
Strainer &
Blowdown Valve

TYPICAL APPLICATIONS

DRIP, TRACER: The **WD700S** thermodynamic steam trap is commonly used as a drip trap on steam mains and steam supply lines. These traps are used on tracing applications; however, thermostatic traps are normally recommended for this service. Supplied with an integral strainer and optional blowdown valve to protect the trap from contamination. The internal working mechanism of the **WD700S** can be completely replaced while the trap body remains in line. Ideal for outdoor applications that are subject to freezing and for superheated steam conditions.

HOW IT WORKS

The thermodynamic trap has cyclic on-off operation with a disk that is pushed open by incoming condensate and closes tightly when steam tries to escape.

FEATURES

- "Quick Change" capsule design for easy in-line repair
- Integral strainer with optional blowdown valve to protect trap from contamination
- High pressure applications up to 600 PSIG
- Hardened stainless steel seat and disc for extended service life even at high pressure
- Single trap will operate over the entire pressure range (4-600 PSIG)
- Unaffected by superheated steam
- Freezeproof when trap is piped in a vertical orientation for complete drainage of condensate
- Weldable body in chrome-moly alloy steel
- Trap will function in any orientation (horizontal preferred)

SAMPLE SPECIFICATION

The steam trap shall be a thermodynamic style in a chrome-moly alloy steel body with an integral strainer and optional blowdown valve. Unit shall have an all stainless steel in-line removable seat and disc capsule assembly. Trap shall be capable of installation in any orientation and self-draining when mounted vertically.

INSTALLATION

Trap can be installed in any position; however, horizontal is preferred. Installation should include isolation valves.

MAINTENANCE

Complete replacement of capsule assembly can be performed while the steam trap remains in line. For full maintenance details see Installation and Maintenance Manual.

OPTIONS

Blowdown valve.

Customized Flanged Connections:

Specify size, face to face dimensions and metallurgy required for application.

MATERIALS

Body	Chrome Moly ASTM A-217, GR WC9
Seat	Stainless Steel, 420F
Seat Gasket	Clad, Non-Asbestos
Cover	Stainless Steel, 416
Disc	Stainless Steel, 420
Retaining Ring	Stainless Steel Spring Wire
Screen	Stainless Steel, 304
Strainer Plug, Pipe Plug	Stainless Steel, 303
Blowdown Valve	Stainless Steel
Flanges	Carbon Steel

WD700S

Thermodynamic Steam Trap

Revised 9/2004

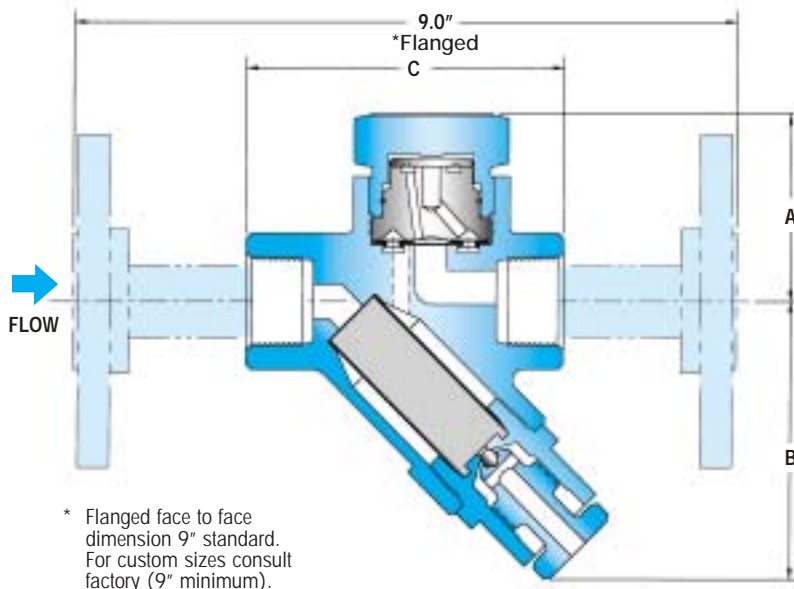

* Flanged face to face dimension 9" standard. For custom sizes consult factory (9" minimum).

WD700S is a Direct Replacement for Yarway Model 721

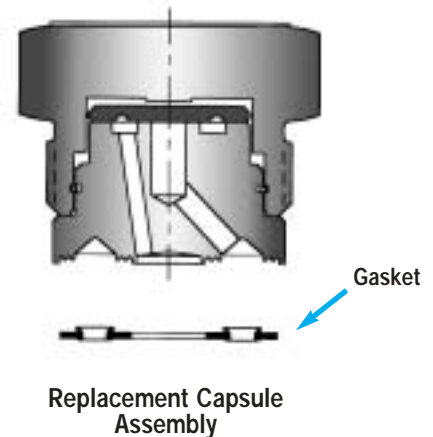

DIMENSIONS & WEIGHTS – inches/pounds					
Size/Model	Connection	A	B	C	Weight (lbs)
Series WD700S & WD700HS (Strainer)					
1/2"	NPT, SW	2.04	2.50	3.16	2
3/4"	NPT, SW	2.04	2.50	3.55	2
1"	NPT, SW	2.04	2.50	6.31	2
Series WD700SB & WD700HSB (Strainer & Blowdown Valve)					
1/2"	NPT, SW	2.04	3.06	3.16	2.25
3/4"	NPT, SW	2.04	3.06	3.55	2.25
1"	NPT, SW	2.04	3.06	6.31	2.25

WD700HS

The **WD700HS** is the high pressure version of the WD700S. The standard model **WD700S** will operate over the entire pressure range, however, the **WD700HS** will operate more efficiently and have a longer service life for pressures over 300 PSIG.

- WD700S** Standard pressure capsule 4-300 PSIG
- WD700HS** High pressure capsule 150-600 PSIG

HOW TO ORDER

Example:

- 1/2" WD700SB** 1/2" connections with integral strainer and blowdown valve.
- 1/2" WD700HSB** 1/2" connections with integral strainer and blowdown valve with high pressure capsule for pressures over 150 PSI.

CAPACITIES – Condensate (lbs/hr)

Model/Size	Pressure (PSIG)																							
	1	2	3	4	5	6	7	8	9	10	20	30	40	50	60	80	100	150	200	300	400	500	600	
WD700S (Cold)	65	90	110	130	140	160	175	180	190	200	280	350	400	440	500	575	650	800	925	1200	1450	1600	1750	
WD700S (Hot)				95	105	115	120	125	130	140	180	220	250	265	280	320	350	405	460	550	600	650	700	
WD700HS (Cold)																		350	400	495	500	620	690	
WD700HS (Hot)																		250	280	330	380	410	450	