

STEAM TRAPS

FM/FSM Series

Manifolds

Watson McDaniel reserves the right to change the designs and/or materials of its products without notice.
©2004 Watson McDaniel Company

Revised 9/2004

Model	FM	FSM
Sizes	1/2", 3/4"	1/2", 3/4"
Connections	NPT, SW	NPT, SW
Body Material	Fabricated Carbon Steel	Forged Steel
PMO Max. Operating Pressure	720 PSIG	600 PSIG
Pressure/Temperature Rating	720 PSIG @ 508°F	600 PSIG @ 500°F

TYPICAL APPLICATION

The **FM /FSM Manifolds** are used for steam distribution to the tracing system and for condensate collection. Typically used in chemical plants, petrochemical plants, textile industries, rubber plants and general industry. Manifolding your distribution and condensate collection system not only cuts down on installation and maintenance time, but also provides freeze protection.

DESCRIPTION FM

The **FM Manifold** is equipped with threaded or socket welded mount holes for ease of installation. Condensate collection manifolds are provided with a built-in siphon tube to minimize bi-phase flow, which reduces water hammer, and allows flash steam space to prevent isolation station freeze damage.

DESCRIPTION FSM

The **FSM Manifold** has a sealing system that utilizes an austenitic stainless steel piston that slides into two rings, one upper made of reinforced graphite, and one lower made of graphite interposed with thin stainless steel plates. The sealing surface is the surface of the piston. By tightening the bonnet nuts that are on the spring washers, a constant load on the upper ring is obtained, securing a tight seal to atmosphere. The same load, through the upper ring and the lantern, is applied to the lower ring that by expanding toward the body wall and toward the surface of the piston when the valve is in the closed position, ensures a perfect seal of the valve against the flow of the fluid.

FEATURES

- Compact design saves valuable plant space
- Available in 4, 6, 8 & 12 branch designs
- Available with preassembled steam trap stations
- Standard designs or custom built manifolds available
- Provides freeze protection
- Cuts down on installation and maintenance time
- On **FSM Model** valve bonnets are long neck type to allow for installation of insulation, keeping temperatures low



FM Manifold



FSM Manifold

MATERIALS – FM

Body	Carbon Steel
------	--------------

MATERIALS – FSM

Body	Forged Steel, A105
Hand Wheel	Sheet Metal
Bonnet	Forged Steel, A105
Valve ring above	Graphite
Valve ring below	Graphite/Stainless Steel
Piston	Stainless Steel, A304

FM Series Manifolds

Revised 9/2004

DIMENSIONS & WEIGHTS – inches / pounds

Description	Condensate Inlet Connection Cl. 3000 Per ANSI B16.11					B Length	Weight (lbs)
	A		# Conn. on Side	# Conn. on Front	Conn. Total		
	Size	Type					
Vertical Coll. Manifold w/ 4 Side Conn. 1/2" NPT Carbon Steel	1/2"	NPT	4	0	4	24	25
Vertical Coll. Manifold w/ 4 Side Conn. 1/2" SW Carbon Steel	1/2"	SW	4	0	4	24	25
Vertical Coll. Manifold w/ 4 Side Conn. 3/4" NPT Carbon Steel	3/4"	NPT	4	0	4	24	27
Vertical Coll. Manifold w/ 4 Side Conn. 3/4" SW Carbon Steel	3/4"	SW	4	0	4	24	27
Vertical Coll. Manifold w/ 4 Side & 2 Front Conn. 1/2" NPT Carbon Steel	1/2"	NPT	4	2	6	24	27
Vertical Coll. Manifold w/ 4 Side & 2 Front Conn. 1/2" SW Carbon Steel	1/2"	SW	4	2	6	24	27
Vertical Coll. Manifold w/ 4 Side & 2 Front Conn. 3/4" NPT Carbon Steel	3/4"	NPT	4	2	6	24	29
Vertical Coll. Manifold w/ 4 Side & 2 Front Conn. 3/4" SW Carbon Steel	3/4"	SW	4	2	6	24	29
Vertical Coll. Manifold w/ 8 Side Conn. 1/2" NPT Carbon Steel	1/2"	NPT	8	0	8	40	40
Vertical Coll. Manifold w/ 8 Side Conn. 1/2" SW Carbon Steel	1/2"	SW	8	0	8	40	40
Vertical Coll. Manifold w/ 8 Side Conn. 3/4" NPT Carbon Steel	3/4"	NPT	8	0	8	40	42
Vertical Coll. Manifold w/ 8 Side Conn. 3/4" SW Carbon Steel	3/4"	SW	8	0	8	40	42
Vertical Coll. Manifold w/ 8 Side & 4 Front Conn. 1/2" NPT Carbon Steel	1/2"	NPT	8	4	12	40	46
Vertical Coll. Manifold w/ 8 Side & 4 Front Conn. 1/2" SW Carbon Steel	1/2"	SW	8	4	12	40	46
Vertical Coll. Manifold w/ 8 Side & 4 Front Conn. 3/4" NPT Carbon Steel	3/4"	NPT	8	4	12	40	48
Vertical Coll. Manifold w/ 8 Side & 4 Front Conn. 3/4" SW Carbon Steel	3/4"	SW	8	4	12	40	48
Vertical Coll. Manifold w/ 12 Side Conn. 1/2" NPT Carbon Steel	1/2"	NPT	12	0	12	56	56
Vertical Coll. Manifold w/ 12 Side Conn. 1/2" SW Carbon Steel	1/2"	SW	12	0	12	56	56
Vertical Coll. Manifold w/ 12 Side Conn. 3/4" NPT Carbon Steel	3/4"	NPT	12	0	12	56	58
Vertical Coll. Manifold w/ 12 Side Conn. 3/4" SW Carbon Steel	3/4"	SW	12	0	12	56	58

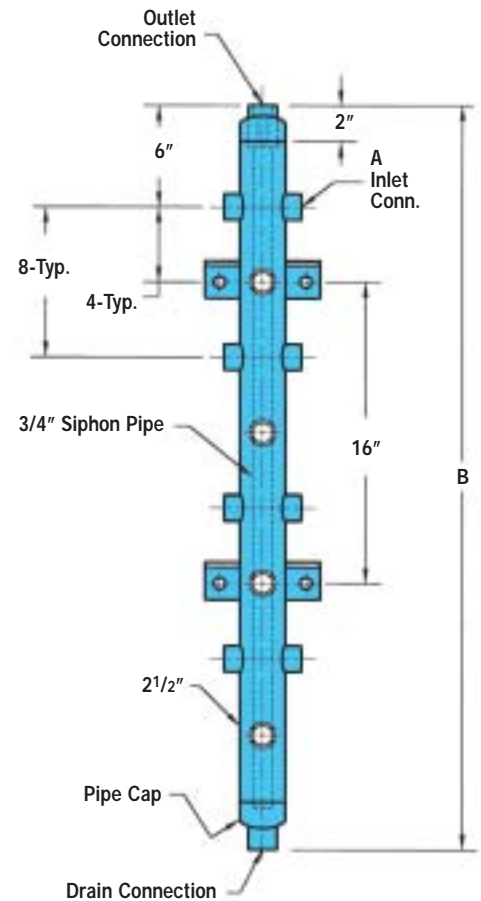
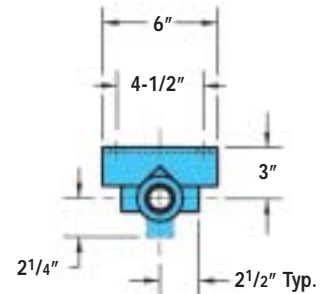

STEAM TRAPS

FSM Series

Manifolds

Watson McDaniel reserves the right to change the designs and/or materials of its products without notice.
©2004 Watson McDaniel Company

Revised 9/2004

DIMENSIONS & WEIGHTS – inches/pounds

Series	L	H	D	C	O	I	S	S1	S2	A	A1	B	B1	No. of Holes	No. of	Weight (lbs)
FSM-4	4.33"	1.61"	3.94"	8.97"	10.63"	6.30"	13.03"			2.79"	1.22"	3.23"	2.79"	4	2(M14)	23
FSM-8	4.33"	1.61"	3.94"	8.97"	10.63"	6.30"		28.1"		2.79"	1.22"	3.23"	2.79"	8	4(M14)	49
FSM-12	4.33"	1.61"	3.94"	8.97"	10.63"	6.30"			36.22"	2.79"	1.22"	3.23"	2.79"	12	6(M14)	72

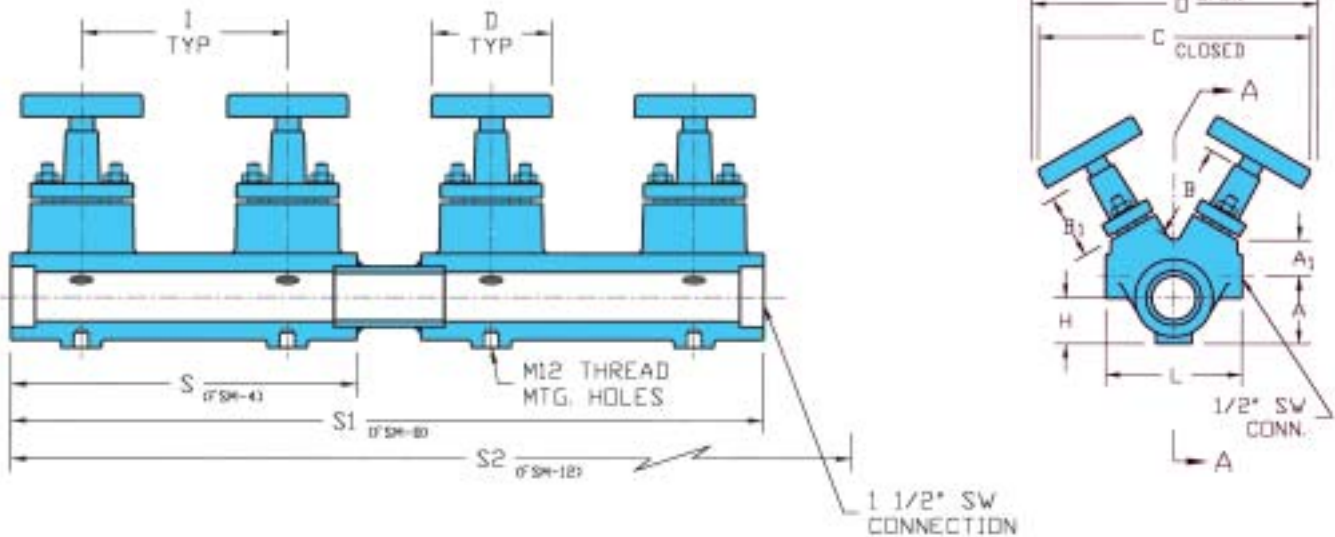

CAPACITIES

Pressure (PSIG)	Condensate lbs/hr ¹	Steam lbs/hr ²
25	1850	160
50	1000	310
75	840	460
100	610	730
125	660	760
150	620	900
200	570	1200
250	535	1500
300	510	1800
400	470	2350
500	460	3000
600	440	3550

¹Saturated condensate discharging into 20 psi backpressure

²Saturated Steam flow @ 5000 ft/min velocity