

SPECIALTY PRODUCTS

WCIY Series

Cast Iron Y-Type Strainers

Watson McDaniel reserves the right to change the designs and/or materials of its products without notice.
©2004 Watson McDaniel Company

Revised 9/2004

Model	WCIY
Sizes	1/2", 3/4", 1", 1 1/4", 1 1/2", 2", 2 1/2", 3", 4"
Connections	NPT, Flanged
Body Material	Cast Iron



PRESSURE/TEMPERATURE RATINGS

NPT 250 PSIG @ 406° F	- Steam
NPT 400 PSIG @ 150° F	- WOG
125# FLG 125 PSIG @ 450° F	- Steam
125# FLG 200 PSIG @ 150° F	- WOG
250# FLG 250 PSIG @ 450° F	- Steam
250# FLG 500 PSIG @ 150° F	- WOG

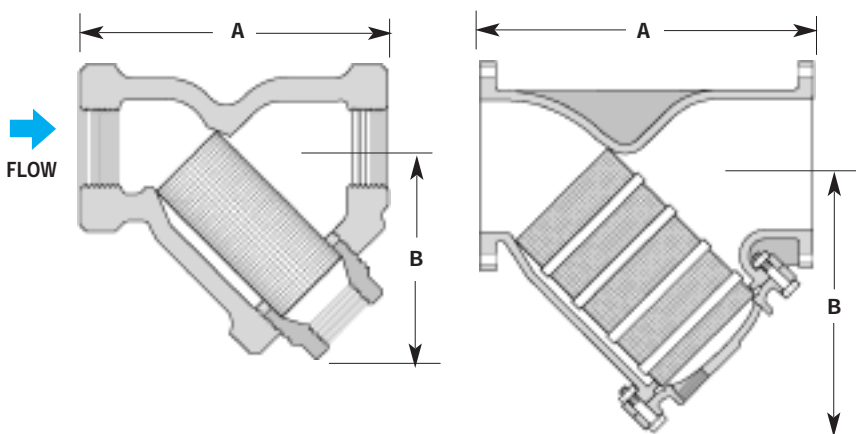

TYPICAL APPLICATIONS

The **WCIY** Y-Strainer is used to strain dirt particles from fluid in pipe lines and provide inexpensive protection for costly pumps, meters, valves, traps, turbines, and compressors.

FEATURES

- Machined seat assures perfect fit for screen
- Blow off connection & easily removable stainless steel cylindrical screens for easy maintenance
- Durable cast iron body

INSTALLATION

The strainer should be installed in the flow direction as indicated on the body in either a vertical down or horizontal pipeline. The strainer must be accessible for periodic cleaning.

DIMENSIONS – inches / pounds

Size/ Connection	Model	A	B	Blowdown NPT	Weight (lbs)	Screen Area
1/2" NPT	WCIY-12-020S250	3 1/4	2 1/4	1/4	2 1/2	5.4
3/4" NPT	WCIY-13-020S250	3 3/4	2 5/8	1/2	3	9.4
1" NPT	WCIY-14-020S250	4	2 3/4	1/2	5	11.9
1 1/4" NPT	WCIY-15-020S250	5	3 3/4	3/4	9	16.2
1 1/2" NPT	WCIY-16-020S250	5 13/16	4	3/4	10	23.2
2" NPT	WCIY-17-020S250	7	5	1	16	35.0
2" 125# FLG	WCIY-17-020F125	9 7/8	6 1/4	1 1/2	36	34.5
2" 250# FLG	WCIY-17-020F250	11 5/8	6 1/2	1 1/2	40	34.5
2 1/2" NPT	WCIY-18-045S250	9 5/16	6	1 1/2	29	47.9
2 1/2" 125# FLG	WCIY18-045F125	11 1/4	7 5/8	1	48	47.3
2 1/2" 250# FLG	WCIY-18-045F250	11 1/16	7	1	52	47.3
3" NPT	WCIY-19-045S250	10 1/8	7	1 1/2	38	64.8
3" 125# FLG	WCIY-19-045F125	12 1/2	8 1/4	1 1/4	86	64.8
3" 250# FLG	WCIY-19-045F250	12 5/8	8	1	86	64.8
4" 125# FLG	WCIY-20-045F125	14 7/8	10 1/8	1 1/4	106	127.2
4" 250# FLG	WCIY-20-045F250	15 1/2	10 3/4	1 1/4	160	127.2

MATERIALS

Body	Cast Iron, A126 CLASS B
Plug	Cast Iron, A126 CLASS B
Cover	Cast Iron, A126 CLASS B
*Screen	Stainless Steel
*Gasket	Blue Guard

*Recommended spare parts.