

SPECIALTY PRODUCTS

WVBSS

Stainless Steel Vacuum Breaker

Watson McDaniel reserves the right to change the designs and/or materials of its products without notice.
©2004 Watson McDaniel Company

Revised 9/2004

Model	WVBSS
Sizes	1/2"
Connections	NPT
Body Material	Stainless Steel
PMO Max. Operating Pressure	300 PSIG
TMO Max. Operating Temperature	752°F
PMA Max. Allowable Pressure	300 PSIG up to 752°F
TMA Max. Allowable Temperature	752°F @ 300 PSIG



TYPICAL APPLICATION

The **WVBSS** Vacuum Breaker is used on heat exchangers, air coils, jacketed kettles, pressing machines, boiler feed water tanks, sparge systems, water lines or anywhere else an unwanted vacuum may occur. The WVBSS allows air to enter the steam or liquid system in order to "break the vacuum" caused by the condensing of steam or draining of liquid from a system. Eliminating vacuum is necessary to allow for proper drainage of liquid from process systems.

HOW IT WORKS

The Vacuum Breaker functions like a simple check valve. Outside air is allowed to enter the system through the vacuum breaker, however, when steam or water try to escape, the vacuum breaker closes off tightly.

FEATURES

- All stainless steel construction
- Small & compact

SAMPLE SPECIFICATION

Vacuum Breakers shall be of all stainless steel construction with a hardened stainless steel ball valve design.

INSTALLATION

Unit must be installed in a vertical position and should be placed at the highest point in the system.

MATERIALS

Body	Stainless Steel, Series 300
Internals	Stainless Steel, Series 300
Nameplate	Stainless Steel, Series 300

DIMENSIONS

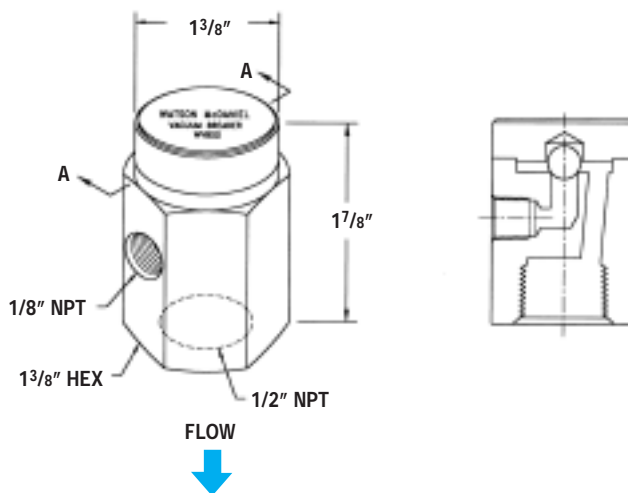

AIR CAPACITIES – (scfm)

Size NPT	in Hg Vacuum					
	2	4	6	8	10	12
1/2"	2.4	3.4	4.0	4.3	4.7	4.9

SPECIALTY