

# SPECIALTY PRODUCTS

## WEH Series

### Exhaust Head

Watson McDaniel reserves the right to change the designs and/or materials of its products without notice.  
©2004 Watson McDaniel Company

Revised 9/2004

Model	WEHC	WEHF
Sizes	1", 1 1/2", 2", 2 1/2", 3", 4", 5", 6", 8", 10"	2 1/2", 3", 4", 5", 6", 8", 10"
Connections	NPT, 125# Flanged	150# Flanged
Body Material	Cast Iron	Carbon Steel



### TYPICAL APPLICATION

The **WEH Series** Exhaust Heads are used to separate entrained water and particles from steam prior to being discharged directly to the atmosphere. Typically used to eliminate water damage to rooftops and other equipment.

### HOW IT WORKS

Exhaust heads use the cyclonic effect where the velocity of the steam is used to generate centrifugal force that whirls the steam and throws the entrained water to the wall of the unit where it is released to a drain below. Correct sizing of exhaust heads for steam service is important in order to assure the highest possible dryness.

### FEATURES

- Up to 99% of particles 10 micron and larger are separated from discharging steam
- Maximizes separation of water and steam
- Contains Vortex Containment Plate

### SAMPLE SPECIFICATION

Steam Exhaust Head shall be a cyclone design for vertical venting to atmosphere. Unit shall have a vortex containment plate feature to prevent re-entrainment of liquid. Exhaust Head to be constructed in cast iron or carbon steel and available in FNPT and flanged connections.

### INSTALLATION

The WEH Steam Exhaust Head must be installed at the top of a vertical vent pipe. Exercise standard piping and structural practices when installing this unit. Proper drainage of the exhaust head is essential for proper operation. Pipe the drain connection of the head to a roof gutter or down spout.

### MATERIALS

WEHC	All Parts Cast Iron
WEHF	All Parts Fabricated Carbon Steel

### HOW TO ORDER

Refer to the capacity chart to determine which model is required to satisfy the application needs.

*Available sizes and connections:*

#### Cast Iron

NPT - 1", 1 1/2", 2", 2 1/2", 3", 4"  
125# Flanged - 4", 5", 6", 8", 10"

#### Carbon Steel

150# Flanged - 2 1/2", 3", 4", 5", 6", 8", 10"

# SPECIALTY PRODUCTS

## WEH Series

### Exhaust Head

Revised 9/2004

#### WEHF (Carbon Steel)

#### WEHC DIMENSIONS, WEIGHTS & CAPACITIES – inches

Size	Inlet Connection	A	B	Drain NPT	Weight (lbs)	Capacity*
1"	NPT	5 <sup>1</sup> / <sub>4</sub>	6 <sup>1</sup> / <sub>8</sub>	1/2	11	160
1 <sup>1</sup> / <sub>2</sub> "	NPT	5 <sup>1</sup> / <sub>4</sub>	6 <sup>1</sup> / <sub>8</sub>	1/2	11	370
2" & 2 <sup>1</sup> / <sub>2</sub> "	NPT	7 <sup>1</sup> / <sub>2</sub>	8 <sup>7</sup> / <sub>8</sub>	3/4	25	1,000
3"	NPT	8 <sup>3</sup> / <sub>4</sub>	11 <sup>1</sup> / <sub>4</sub>	3/4	40	2,100
4"	NPT	10	11 <sup>1</sup> / <sub>4</sub>	1	50	2,700
4"	FLG	10	15	1	68	2,700
5"	FLG	13	14	1 <sup>1</sup> / <sub>2</sub>	90	4,000
6"	FLG	14 <sup>3</sup> / <sub>4</sub>	18 <sup>3</sup> / <sub>4</sub>	1 <sup>1</sup> / <sub>2</sub>	115	6,000
8"	FLG	18	20	2	190	10,500
10"	FLG	23	24	2	335	16,000

\*Capacity in pounds of exhaust steam/hour at atmosphere pressure of 14.7 PSIA.

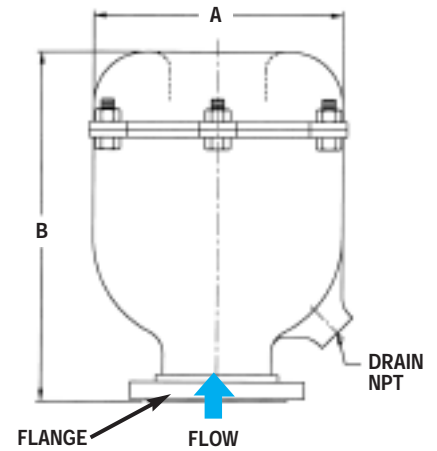
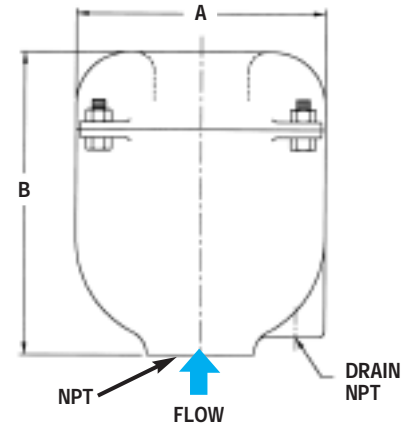

#### WEHF (Carbon Steel)

#### WEHF DIMENSIONS, WEIGHTS & CAPACITIES – inches

Inlet Size	Inlet Connection	A	B	Drain NPT	Weight (lbs)	Capacity*
2 <sup>1</sup> / <sub>2</sub> "	FLG	8 <sup>5</sup> / <sub>8</sub>	16	1	55	1,000
3"	FLG	10 <sup>3</sup> / <sub>4</sub>	19	1 <sup>1</sup> / <sub>2</sub>	65	1,600
4"	FLG	14	24	1 <sup>1</sup> / <sub>2</sub>	100	2,700
5"	FLG	16	26	1 <sup>1</sup> / <sub>2</sub>	130	4,000
6"	FLG	18	30	1 <sup>1</sup> / <sub>2</sub>	140	6,000
8"	FLG	20	36	2	240	10,500
10"	FLG	24	42	2	390	16,000

\*Capacity in pounds of exhaust steam/hour at atmosphere pressure of 14.7 PSIA.

