

SPECIALTY PRODUCTS

Ejectors

Syphons, Eductors, Exhausters & Injectors

Watson McDaniel reserves the right to change the designs and/or materials of its products without notice.
©2004 Watson McDaniel Company

Revised 9/2004

Model	W-EJECT, W-ELL, W-LM
Sizes	1/2", 3/4", 1", 1 1/4", 1 1/2", 2"
Connections	NPT
Body Material	Bronze (1/2" - 1 1/2") Cast Iron (2")
PMO Max. Operating Pressure	100 PSIG
TMO Max. Operating Temperature	130°F
PMA Max. Allowable Pressure	250 PSIG up to 450°F
TMA Max. Allowable Temperature	450°F @ 250 PSIG



W-ELL
W-LM

TYPICAL APPLICATION

Watson McDaniel **Ejectors** perform a variety of functions depending on the application and motive fluid (steam or water) used. See performance charts on the following pages. Applications include: exhausting, agitating, aerating, circulating, pumping and mixing.

HOW IT WORKS

Using water, steam or air pressure as the motive force, ejectors operate on the principle that a high velocity flow through a nozzle will create a pressure drop in the area around the nozzle discharge. The resulting vacuum will induce flow into the secondary inlet of the ejector.

FEATURES

- No moving parts
- Can be used with water or steam pressure
- Submersible
- Available in cast iron or bronze

SAMPLE SPECIFICATION

Ejectors shall be constructed from bronze or cast iron. Units shall be capable of using steam, water or air as a motive force.

INSTALLATION

See installation examples on following page.

MATERIALS

Body (1/2" - 1 1/2")	Bronze
Body (2")	Cast Iron
Nozzles (all sizes)	Bronze

SPECIALTY PRODUCTS

Ejectors

Syphons, Eductors, Exhausters & Injectors

Revised 9/2004

W-EJECT

DIMENSIONS & WEIGHTS – inches / pounds

Size	Connection Sizes			Dimensions			
	Suction	Discharge	Inlet	A	B	C	D
Bronze Body & Nozzles							
1/2"	1/2	1/2	1/4	3 1/4	17/16	11 3/16	1 1/8
3/4"	3/4	3/4	3/8	4	1 1/2	2 1/2	1 3/8
1"	1	1	1/2	5 1/8	2 1/4	2 7/8	1 5/8
1 1/4"	1 1/4	1 1/4	3/4	5 7/8	2 7/16	3 7/16	1 13/16
1 1/2"	1 1/2	1 1/2	3/4	6 1/4	2 11/16	3 9/16	1 15/16
Cast Iron Body with Bronze Nozzles							
2"	2	2	1	7 1/4	3 1/8	4 1/8	2 3/8

Connections are female NPT

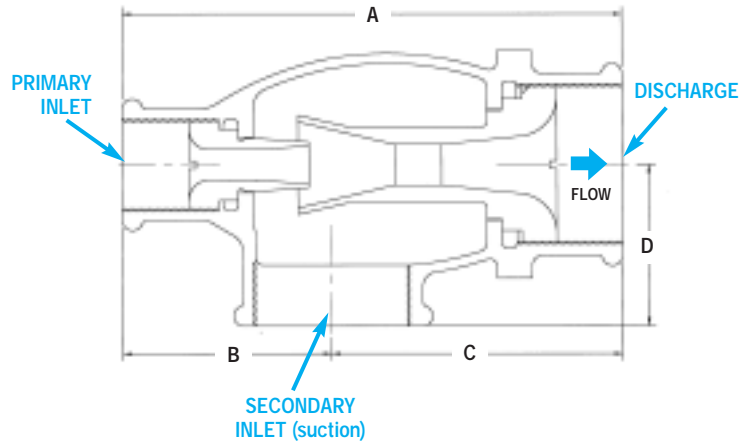

W-ELL / W-LM

Bronze Body & Nozzles

DIMENSIONS & WEIGHTS – inches / pounds

Size	Connection Sizes			Dimensions		
	Suction	Discharge	Inlet	A	B	D
3/4"	3/4	3/4	1/2	5 13/16	2	1 3/8
1"	1	1	3/4	7 1/8	2 5/16	1 3/4
1 1/4"	1 1/4	1 1/4	1	9	2 7/16	2 1/8

Connections are male NPT

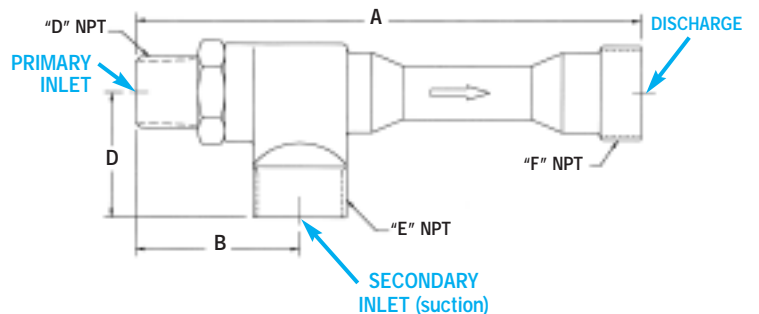

Ejectors shown Pumping Fluid

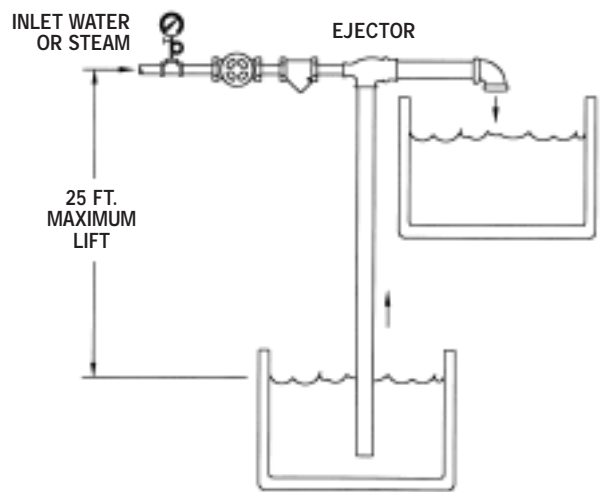
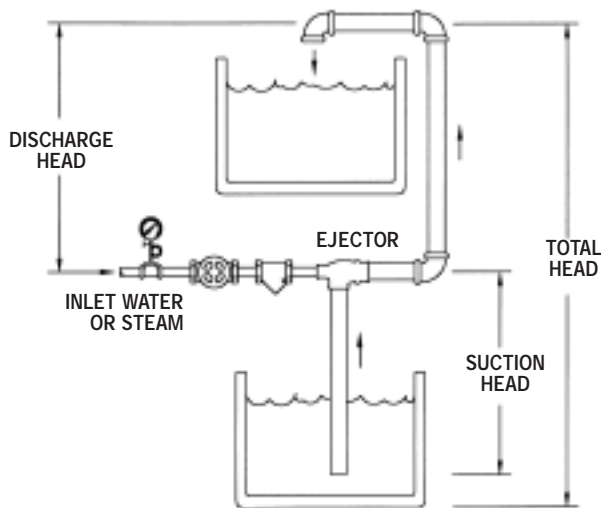

It is always desirable to keep the Ejector as close to the actual liquid being pumped as possible. The maximum height the liquid can be pumped depends on the pressure of the "motive" liquid or steam available. Please refer to the capacity graphs for maximum flow rates and maximum achievable heads.

The maximum height that water or any liquid with a specific gravity of one can be lifted is 27 ft. Increases in the temperature of the liquid you are trying to lift will cause this maximum height to decrease. We don't recommend pumping liquid in excess of 130°F. Please consult factory with any specific application.

SPECIALTY PRODUCTS

Ejector Sizing

Watson McDaniel reserves the right to change the designs and/or materials of its products without notice.
©2004 Watson McDaniel Company

Revised 9/2004

Example 1

A #14 1" Ejector using 60 lbs. of steam pressure as a motive force will pump water to a maximum height of 60 ft. When pumping water to a height of 53 ft. using 60 lbs of steam pressure the amount of water being pumped is 650 Gal/hr.

Example 2

A #14 1" Ejector using 60 lbs. of water pressure as a motive force will pump water to a maximum height of 40 ft. When pumping water to a height of 20 ft. using 60 lbs of water pressure the maximum amount of water being pumped is 700 Gal/hr.

#12 (1/2") Water Ejector

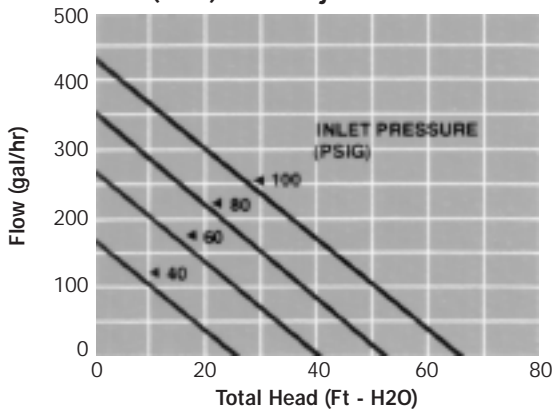

#12 (1/2") Steam Ejector

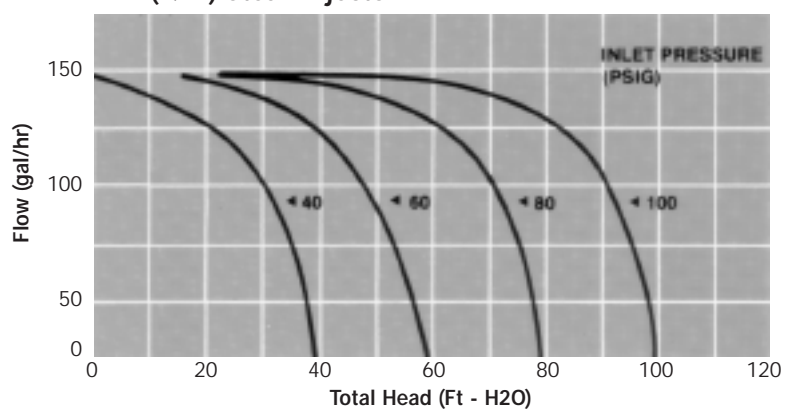

#13 (3/4") Water Ejector

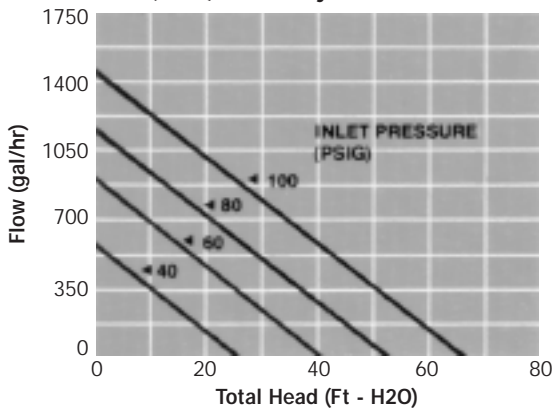

#13 (3/4") Steam Ejector

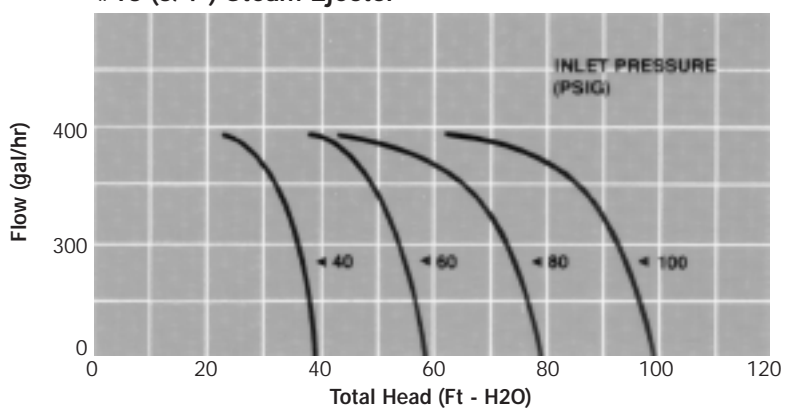

#14 (1") Water Ejector

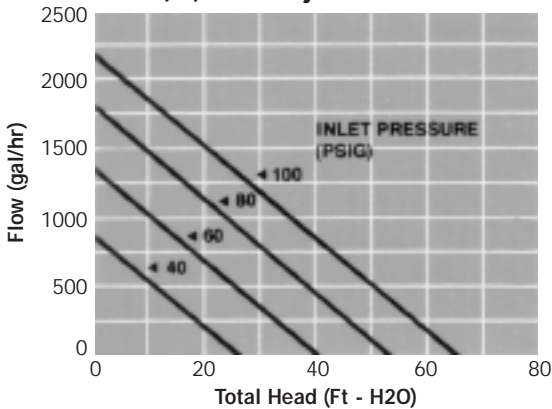

#14 (1") Steam Ejector

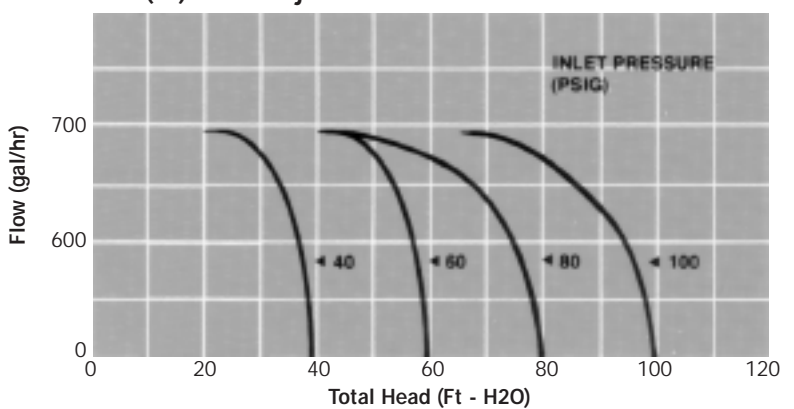

SPECIALTY

Ejector Sizing

Revised 9/2004

#15 (1 1/4") Water Ejector

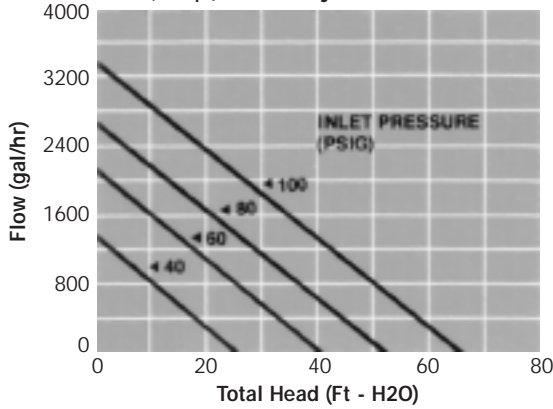

#15 (1 1/4") Steam Ejector

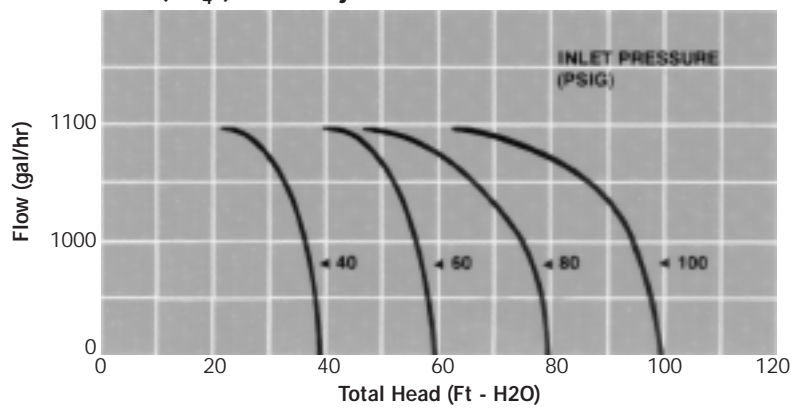

#16 (1 1/2") Water Ejector

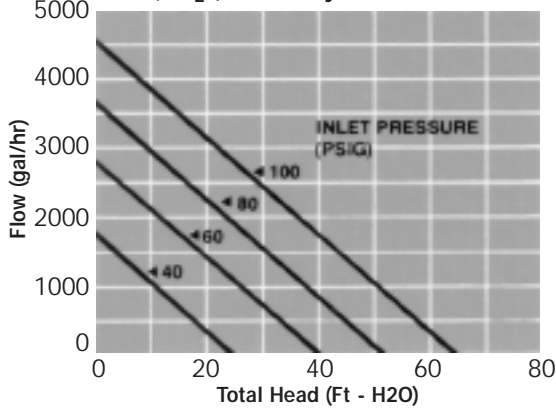

#16 (1 1/2") Steam Ejector

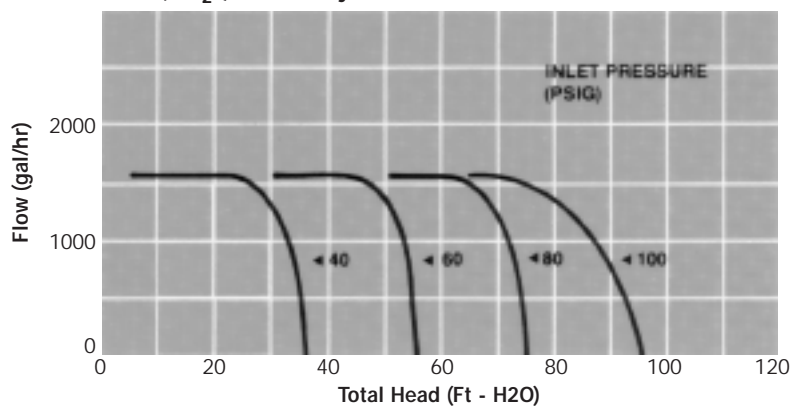

#17 (2") Water Ejector

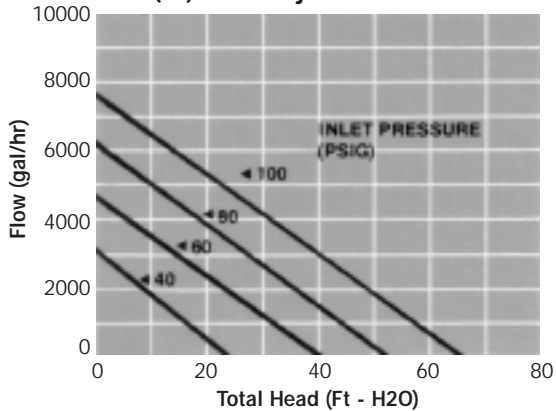

#17 (2") Steam Ejector

