

REGULATOR/PILOT COMBINATIONS

HDT

Pilot-Operated Temperature Regulating Valve

Watson McDaniel reserves the right to change the designs and/or materials of its products without notice.
©2002 Watson McDaniel Company

Revised 9/2004

HD Regulating Valve with "T" Temperature Pilot

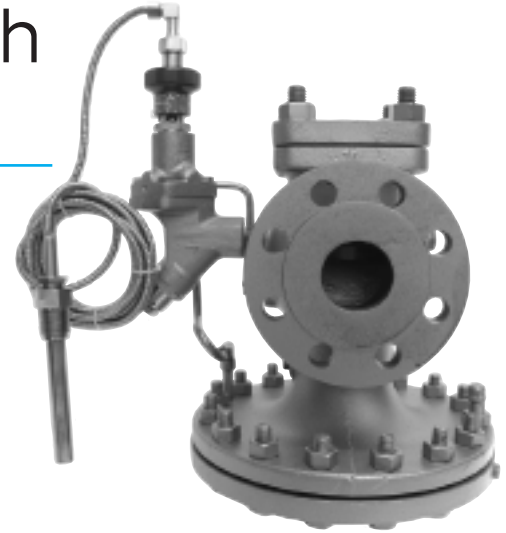

- **Temperature Control Range: 60°–260°F**
- **Inlet Pressure Max: 300 PSIG**
Inlet Pressure Min: 5 PSIG

The HD-Series is the upgraded model for the D-Series Regulator. HD & D internal components and pilots are interchangeable.

TYPICAL APPLICATIONS

The HD or D Regulator with the "T" Temperature Pilot is used for controlling temperature in various processes and systems, such as Oil Heaters, Ovens, Process Heaters, Vats, Dryers, and Jacketed Kettles.

FEATURES

- Temperature adjustment made simple and easy by rotating an adjustment knob to the desired temperature setting
- Thermostatic sensing bulb comes with 8-ft. or 15-ft. capillary. Additional lengths up to 25-ft. max.
- Capillary is armored to protect against damage
- Optional stainless steel sensing bulb and capillary
- Overheat protection bellows is incorporated into sensing bulb. 200°F overheat protection up to 350°F
- Can be used with Pressure Pilots for simultaneous control of pressure and temperature
- Hardened stainless steel trim on regulator for extended service life
- Full port strainer and blow-down valve on pilot adapter to eliminate failure caused by contaminated steam systems

OPTIONS

- Temperature Pilot can be combined with Pressure and Solenoid pilots.
- Additional capillary lengths can be ordered in 5-ft. increments; up to 25-ft. maximum length.
- Wells are available in 316 stainless steel.
- Longer wells can be supplied.
- Low pressure (under 12 PSI) temperature pilot.
- Consult factory for other options.

TEMPERATURE-ADJUSTING RANGES

Temperature	Identifying Colors
60 - 120°F (16 - 49°C)	yellow
100 - 160°F (38 - 71°C)	black
120 - 180°F (49 - 82°C)	blue
160 - 220°F (71 - 104°C)	red
200 - 260°F (93 - 127°C)	green

* Other ranges available; consult Factory.

MATERIALS

	D-SERIES	HD-SERIES
Body	Cast Iron	Ductile Iron
Cover	Cast Iron	Ductile Iron
Gasket	Garlock 3400	Garlock 3400
Cover Screws	Steel	Steel
Pilot Adapter	Cast Iron	Ductile Iron
Screen	Stainless Steel	Stainless Steel
Tubing	Copper	Copper
Valve Seat	Hardened SST (55Rc)	Hardened SST (55Rc)
Valve Disc	Hardened SST (55Rc)	Hardened SST (55Rc)
Diaphragm	Phosphor Bronze	Phosphor Bronze

REGULATOR/PILOT COMBINATIONS

HDT

Pilot-Operated Temperature Regulating Valve

Revised 9/2004

DIMENSIONS D-Series – inches / pounds									
Size	Face-To-Face			B	C	D	E	Weight (lbs)	
	NPT	125#	250#					NPT	FLG
1/2"	5 1/8			5 1/8	8 1/4	5 7/8	6 1/8	18	
3/4"	5 1/2			5 1/2	8 1/4	6 1/2	6 3/8	21	
1"	6 1/8			6 1/8	8 1/4	7	6 5/8	25	
1 1/4"	8 1/2			7	9 1/4	8 3/4	7 1/8	45	
1 1/2"	9 1/2			7 1/8	9 1/4	8 3/4	7 5/8	55	
2"	9 3/4	9 1/2	9 5/8	7 1/8	9 1/4	10 7/8	8 1/4	90	105
2 1/2"		10	10 5/8	8 3/4	9 1/4	11 3/4	8 5/8		135
3"		11	11 3/4	9 1/8	9 1/4	13 1/4	9 1/8		180

DIMENSIONS HD-Series – inches / pounds									
Size	Face-To-Face			B	C	D	E	Weight (lbs)	
	NPT	150#	300#					NPT	FLG
1/2"	4 3/8			5 1/2	9 1/4	6 1/2	6 1/2	18	
3/4"	4 3/8			5 1/2	9 1/4	6 1/2	6 1/2	18	
1"	5 3/8	5 1/2	6	6 1/4	9 1/4	7	8 1/4	23	35
1 1/4"	7 1/4			7 3/8	9 1/4	8 3/4	7 1/4	43	
1 1/2"	7 1/4	6 7/8	7 3/8	7 3/8	9 1/4	8 3/4	7 1/4	43	60
2"	7 1/2	8 1/2	9	8 1/4	9 1/4	10 7/8	7 1/2	65	85
2 1/2"		9 3/8	10	9	9 1/4	11 3/4	7 3/4		105
3"		10	10 3/4	8 7/8	9 1/4	13 1/4	8 1/2		145
4"		11 7/8	12 1/2	10 7/8	9 1/4	14 3/4	9 1/2		235
6"		15 1/8	16	14 1/8	9 3/4	19 3/4	10 3/4		470

HOW TO ORDER

"T" TEMPERATURE PILOT

Specify:

- Temperature range from the chart or indicate the set temperature of the process you wish to control.
- The length of capillary required. 8-ft. or 15-ft. standard. Maximum length: 25-ft. in 5-ft. increments.
- Bulb type needed:
T, TU, TUBW, TUSW, TBW & TSW.

REGULATOR BODY

Specify:

- HD or D regulator body.
- Regulator size or capacity.
- End connections (threaded, 125/150/250/300# flanged).

RECOMMENDED PRESSURE

Differential Pressure: 10 PSIG minimum

Minimum Inlet Pressure: 5 PSIG*

OPTION –

With Standard Pilot: 15 PSIG minimum

With Low Pressure Pilot: 5 PSIG minimum

*Minimum Inlet Pressure for Temperature Regulator: 5 PSIG

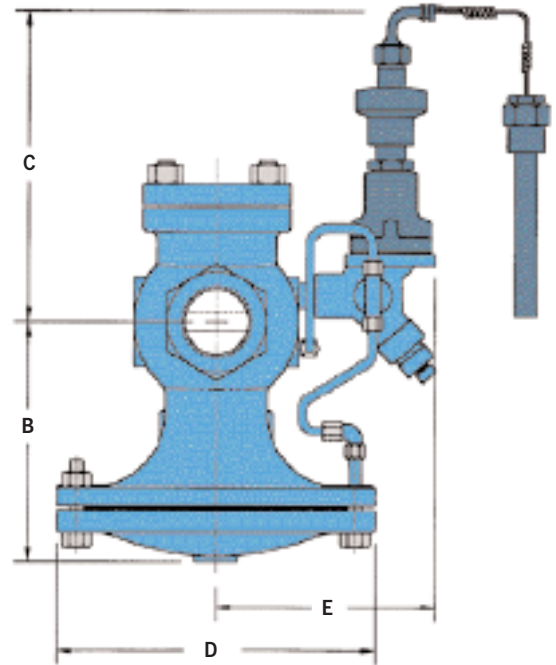

REGULATORS

HOW IT WORKS

The purpose of the temperature pilot is to control the operation of the temperature regulating valve. A sensing bulb filled with liquid is used as a thermostat to monitor the temperature of whatever is being heated. The sensing bulb is connected to the temperature pilot by a length of capillary tubing. When the sensing bulb is heated the liquid inside expands and in turn expands a bellows inside the temperature pilot. The expansion and contraction of this bellows is what controls the operation of the temperature regulating valve.

