

PILOTS

"A" Pilot

Air Pilot for HD & D Regulating Valves

Watson McDaniel reserves the right to change the designs and/or materials of its products without notice.
©2004 Watson McDaniel Company

Revised 9/2004

Air Pilot

- **Pressure Control Range: 3 -200 PSIG**
- **Temperature Range: 0° -350°F when used with PTL & PTR controllers**



TYPICAL APPLICATIONS

The "A" Air Pilot used with either the HD or D Regulator control steam pressure on steam mains and process equipment. The "A" Air Pilot can also be used in conjunction with the PTR or PTL pneumatic controllers for controlling temperature in process applications. The significant advantage of the "A" Air Pilot over standard spring loaded pilots is that pressure adjustments to the regulator can be made from a remote location. Regulator placed in a difficult to reach or inaccessible location can now be adjusted by a control panel board placed in a convenient location.

HOW IT WORKS

When air pressure is applied to the upper chamber of the air pilot it exerts a downward force on the air pilot's diaphragm. This force controls the outlet pressure of the steam through the regulating valve. The control process is similar to a spring loaded pressure pilot except that the air pressure takes the place of the spring. There are three separate models of air pilots that make up the complete range depending on the steam pressure that needs to be controlled and the control air pressure available. See Pressure Adjusting Ranges Chart.

FEATURES

- Pressure adjustments of the regulator can be done from a remote location
- Air-operated pilot insures instant response and extremely accurate control
- Full port strainer and blow-down valve on pilot adapter to eliminate failure caused by contaminated steam systems
- Control pressure settings within ± 1 PSIG

DIMENSIONS – inches

Model	A	B
A1	5 ¹ / ₄	5
A4	5 ¹ / ₄	7 ⁷ / ₈
A6	5 ¹ / ₄	9 ¹ / ₂

PRESSURE ADJUSTING RANGES

Model	Reduced Pressure Range	Description
A1	3-35 PSIG	1:1 ratio of steam pressure to control air pressure
A4	3-100 PSIG	4:1 ratio of steam pressure to control air pressure
A6	20-200 PSIG	6:1 ratio of steam pressure to control air pressure

The larger Diaphragm area of the "A4" & "A6" Air Pilots allows the use of low control air pressure to regulate higher pressure steam

MATERIALS

Pilot Body & Cover	Ductile Iron
Gasket	Garlock 3400
Cover Screws	Steel, GR5
Head & Seat Assembly	Hardened SST (55Rc)

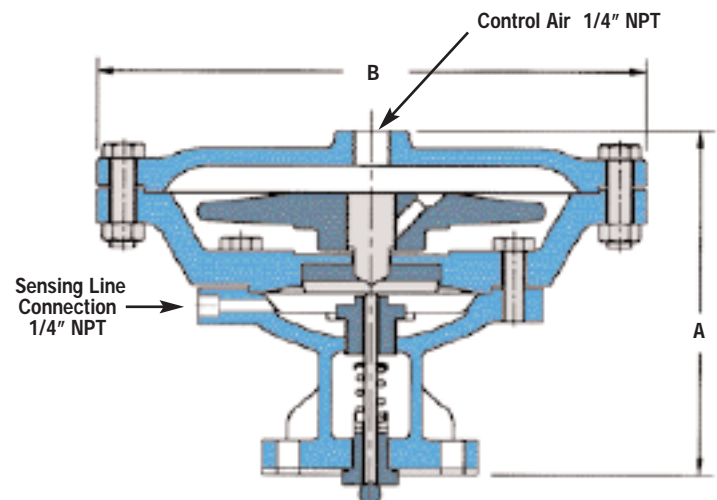

"A" Pilot

Air Pilot for HD & D Regulating Valves

Revised 9/2004

CONTROL PANEL BOARDS

There are three different options of remote control panel boards that can be used along with the "A" Air Pilots. Supply air is fed directly through the control panel board to the air pilot. You should choose one of the three options of control panel boards when using the air piloted regulators.

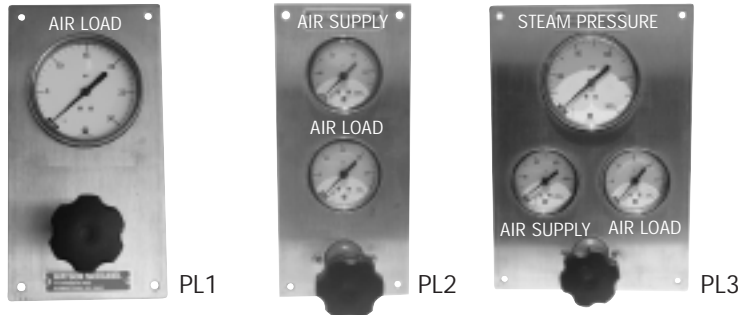

PL1

The PL1 is made up of an air pressure regulator with adjustment knob and pressure gauge that measures the amount of air pressure going to the pilot. Steam pressure of the system is controlled by adjusting the air pressure regulator.

PL2

The PL2 is the same as the PL1 except that it has an extra air pressure gauge for measuring the supply air pressure to the control panel board.

PL3

The PL3 is the same as the PL2 except that it has a steam pressure gauge for measuring steam pressure on outlet side of the regulating valve.

Recommended Pressures

Differential Pressure: 10 PSIG (min.)

Inlet Pressure: 15 PSIG (min.)

Outlet Pressure: 5% of inlet pressure for inlet pressures to 100 PSIG (3 PSIG min.). 10% of the inlet pressure for inlet pressures over 100 PSIG.

Air Supply Pressure: 3 to 35 PSIG

HOW TO ORDER

"A" AIR PILOT

Specify:

- Air Pilot A1, A4, or A6
- Remote Control Panel Board PL1, PL2, or PL3

REGULATOR BODY

Specify:

- HD or D regulator body.
- Regulator size or capacity and pressures of steam required.
- End connections (threaded, 125/150/250/300# flanged).

RECOMMENDED PRESSURE

Differential Pressure: 10 PSIG minimum

Minimum Inlet Pressure: 15 PSIG*

*Minimum Inlet Pressure for Temperature Regulator: 5 PSIG

Pressure Reducing Station Using HD Regulator with an Air Pilot

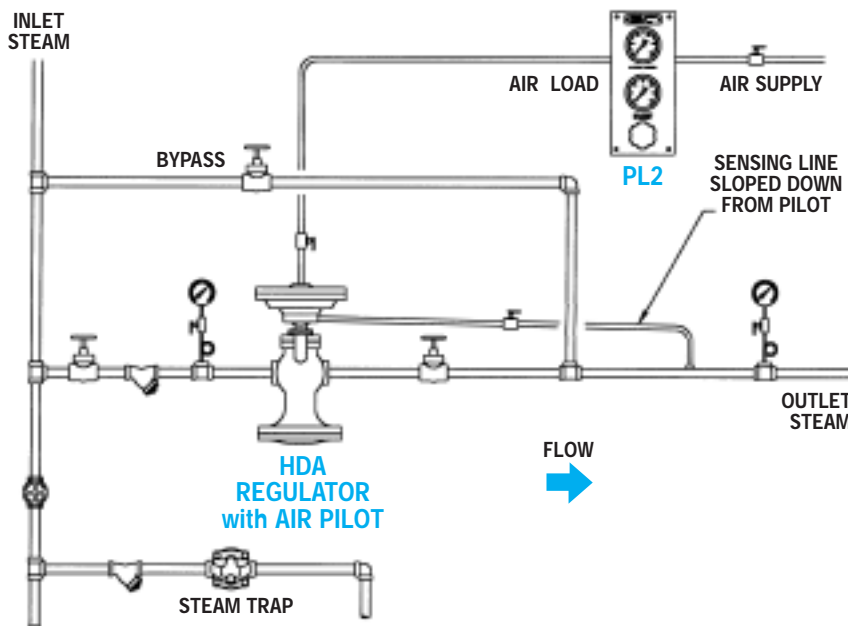

DESCRIPTION OF OPERATION

The "A" Air Pilot is being used in conjunction with the PL2 Control Panel Board to regulate steam pressure. A small air regulator on the panel board can be adjusted to control the air pressure to the pilot. One gauge on the panel board measures air line pressure to the panel board and the other gauge shows the air pressure being sent to the pilot. Depending on the air pilot model chosen (A1, A4, A6), there will be a 1:1, 4:1, or 6:1 ratio of outlet steam pressure to air pressure.