

SERIES-A, SERIES-H, SERIES-S

Noise Attenuation for Pressure Regulating Valves

Watson McDaniel reserves the right to change the designs and/or materials of its products without notice.
©2004 Watson McDaniel Company

Revised 9/2004

Noise Attenuation Equipment is used to reduce unwanted or excessive noise that commonly occurs in pressure reducing stations.

Series-A ORIFICE PLATE

Noise Reduction Capability: 5-10 dBA



Series-A Orifice Plate

HOW IT WORKS

The **Series-A** Orifice Plate with its drilled orifice pattern is installed after the pressure regulating valve to smooth out turbulence caused by the pressure drop across the regulator. Noise reduction levels of **5-10 dBA** can typically be achieved.

INSTALLATION

Series-A Orifice Plate is installed between ANSI flanges immediately after the regulator. If the regulator is a flanged unit, the orifice plate is placed at the flange outlet connection.

REGULATORS

Series-A Typical Hook-up

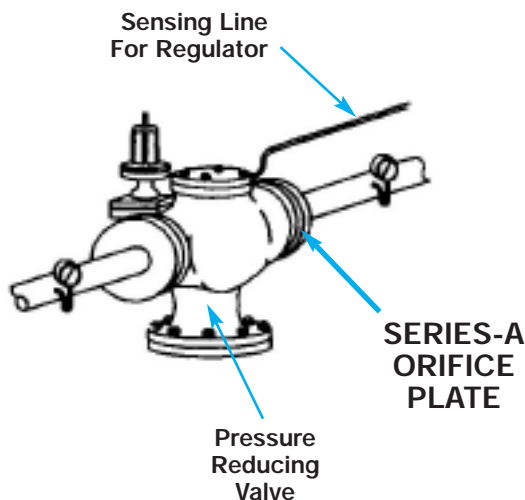

Series A Dimensions

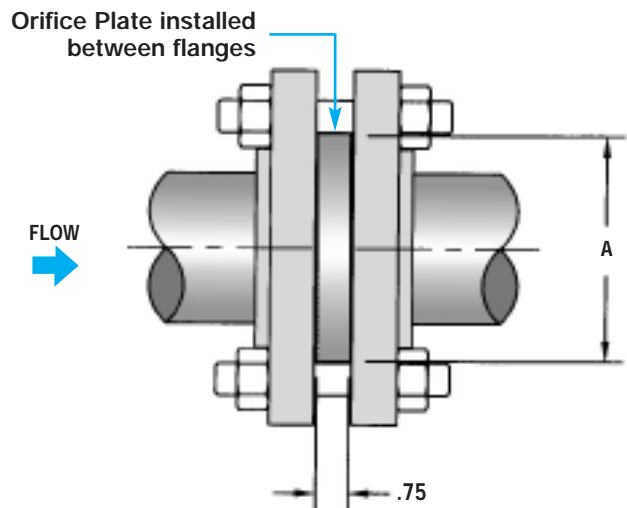

Series-A DIMENSIONS – inches

Pipe Size	Series A 125# Flange	Series A 250# Flange
2"	6	4 ³ / ₁₆
2 ¹ / ₂ "	7	4 ¹⁵ / ₁₆
3"	7 ¹ / ₂	5 ¹¹ / ₁₆
4"	9	6 ¹⁵ / ₁₆
6"	11	9 ¹¹ / ₁₆

Noise Attenuation for Pressure Regulating Valves

Revised 9/2004

Noise Attenuation Equipment is used to reduce unwanted or excessive noise that commonly occurs in pressure reducing stations.

Series-H ACOUSTIC SILENCER

Noise Reduction Capability: 20-30 dBA

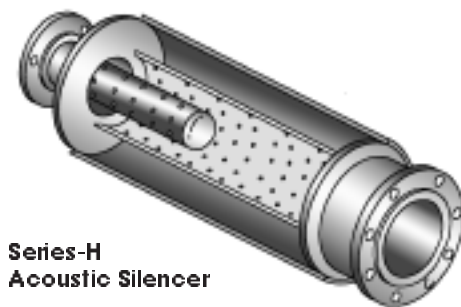

Series-H Dimensions

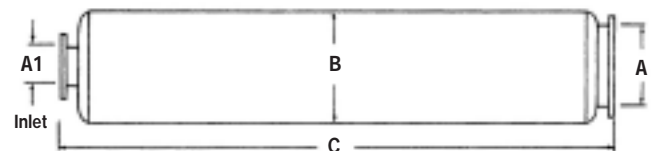

HOW IT WORKS

The **Series-H** Acoustic Silencer incorporates a **Dual Diffuser** tube design. The inner tube has a drilled orifice pattern and the outer tube contains an integral layer of sound absorbing insulation. Noise reduction levels of **20-30 dBA** can typically be achieved.

INSTALLATION

The **Series-H** Diffuser Tube should be installed immediately downstream of the regulator.

Series-H DIMENSIONS – inches

Model	A1	A	B	C	Weight (lbs)
LCV-8	4	8	14	57	145
LCV-10	6	10	16	71	210
LCV-12	6	12	18	81	295

Series-H Typical Hook-up

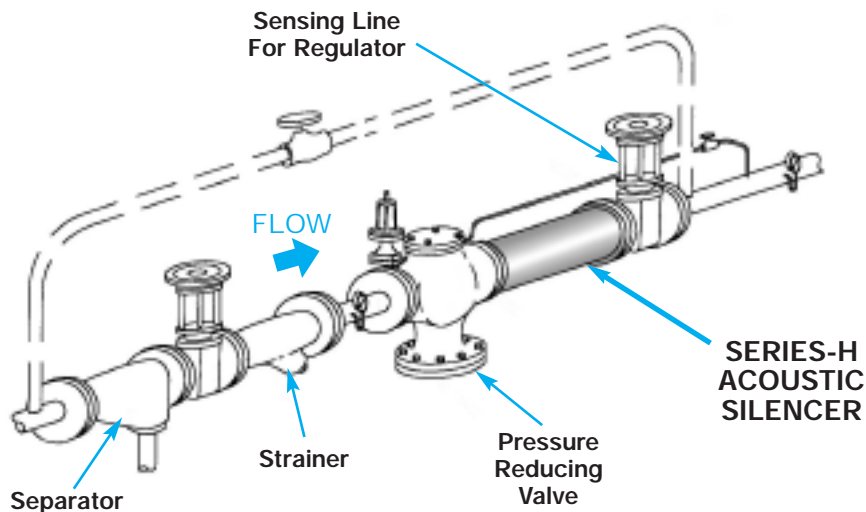

SERIES-S

Noise Attenuation for Pressure Regulating Valves

Watson McDaniel reserves the right to change the designs and/or materials of its products without notice.
©2004 Watson McDaniel Company

Revised 9/2004

Series-S ACOUSTIC DIFFUSER

Noise Reduction Capability: 10-15 dBA

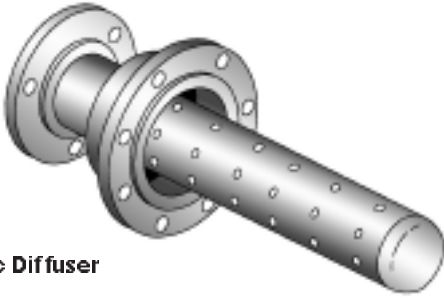

**Series-S
Acoustic Diffuser**

HOW IT WORKS

The **Series-S** Acoustic Diffuser incorporates a single tube with a drilled orifice pattern which reduces downstream turbulence. Noise reduction levels of **10-15 dBA** can typically be achieved.

INSTALLATION

The **Series-S** Diffuser Tube should be installed immediately downstream of the regulator.

Series-S Typical Hook-up

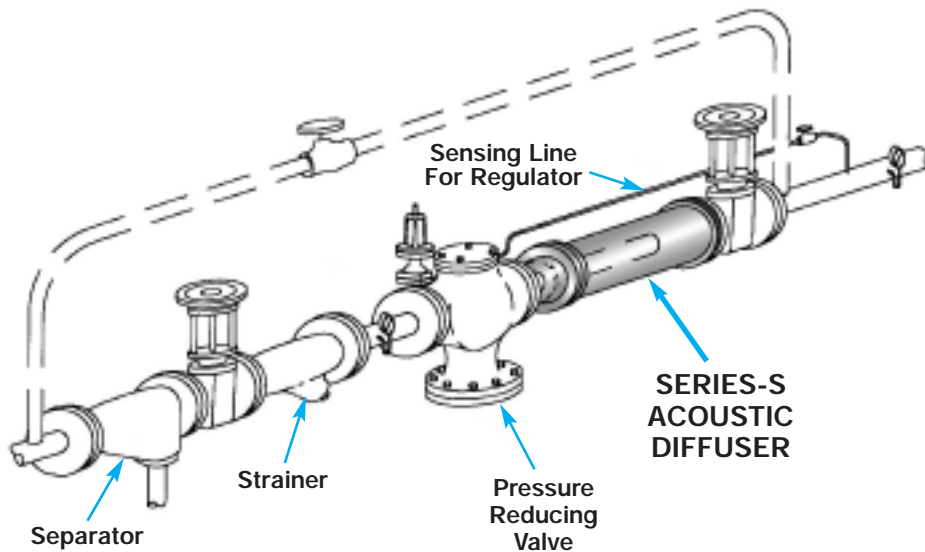

Model Selection Chart for Series-S Diffuser

Steam Capacity (lbs/hr)	Valve Inlet Pressure (PSIG)															
	15	20	25	30	40	50	60	75	90	100	125	150	175	200	225	250
1000	S-3	S-3	S-3	S-3	S-3	S-3	S-3	S-3	S-3	S-3	S-3	S-3	S-3	S-3	S-3	S-3
1500	S-3	S-3	S-3	S-3	S-3	S-3	S-3	S-3	S-3	S-3	S-3	S-3	S-3	S-3	S-3	S-3
2000	S-4	S-4	S-4	S-4	S-4	S-4	S-4	S-4	S-4	S-4	S-4	S-4	S-4	S-4	S-4	S-4
3000	S-4	S-4	S-4	S-4	S-4	S-5	S-5	S-5	S-5	S-5	S-5	S-5	S-5	S-5	S-5	S-5
4000	S-5	S-5	S-5	S-5	S-5	S-5	S-5	S-5	S-5	S-5	S-5	S-5	S-5	S-5	S-5	S-5
6000	S-6	S-6	S-6	S-6	S-6	S-6	S-6	S-6	S-6	S-6	S-6	S-6	S-6	S-6	S-6	S-6
8000	S-8	S-8	S-8	S-8	S-8	S-8	S-8	S-8	S-8	S-8	S-8	S-8	S-8	S-8	S-8	S-8
10000	S-8	S-8	S-8	S-8	S-8	S-8	S-8	S-8	S-8	S-8	S-8	S-8	S-8	S-8	S-8	S-8

Noise Attenuation for Pressure Regulating Valves

Revised 9/2004

Series-S Dimensions – inches						
Model	Inlet		Outlet	NPT x Weld Dimensions		
	NPT	FLG	FLG/BW	B	C	D
S-3	3/4		2	5 1/2	13 1/2	2 3/8
S-3	1		2	5 1/2	13 1/2	2 3/8
S-4	3/4		4	6 1/2	13 1/2	4 1/2
S-4	1		4	6 1/2	13 1/2	4 1/2
S-4	1 1/4		4	6 1/2	13 1/2	4 1/2
S-4	1 1/2		4	6 1/2	13 1/2	4 1/2
S-4	2		4	6 1/2	13 1/2	4 1/2
S-5	3/4		4	6 1/2	16 1/2	4 1/2
S-5	1		4	6 1/2	16 1/2	4 1/2
S-5	1 1/4		4	6 1/2	16 1/2	4 1/2
S-5	1 1/2		4	6 1/2	16 1/2	4 1/2
S-5	2		4	6 1/2	16 1/2	4 1/2
S-5	2 1/2	2 1/2	4	6 1/2	16 1/2	4 1/2
S-6	1 1/4		6	8	14	5 5/8
S-6	1 1/2		6	8	14	5 5/8
S-6	2		6	8	14	5 5/8
S-6	2 1/2	2 1/2	6	8	14	5 5/8
S-6	3	3	6	8	14	5 5/8
S-8	1 1/2		8	10	17	8 5/8
S-8	2		8	10	17	8 5/8
S-8	2 1/2	2 1/2	8	10	17	8 5/8
S-8	3	3	8	10	17	8 5/8
S-8	4	4	8	10	17	8 5/8
S-10	2		12	12	14	12 3/4
S-10	2 1/2	2 1/2	12	12	14	12 3/4
S-10	3	3	12	12	14	12 3/4
S-10	4	4	12	12	14	12 3/4
S-10	6	6	12	12	14	12 3/4
S-12	2 1/2	2 1/2	12	12	21	12 3/4
S-12	3	3	12	12	21	12 3/4
S-12	4	4	12	12	21	12 3/4
S-12	6	6	12	12	21	12 3/4

Note: 150 & 300 # flanges available

NPT x Weld

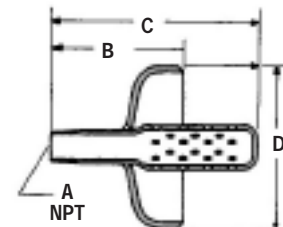

Flanged x Weld

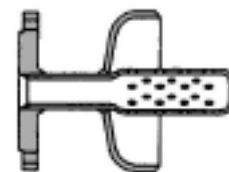

NPT x Flanged

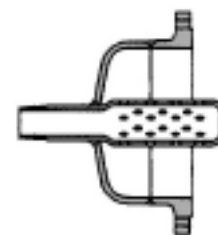

Flanged x Flanged

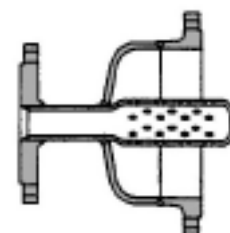

REGULATORS