

LIQUID DRAINERS

WLDE Series

Float Type Liquid Drain Trap

Watson McDaniel reserves the right to change the designs and/or materials of its products without notice.
©2004 Watson McDaniel Company

Revised 9/2004

Model	WLDE
Sizes	1 1/2", 2", 2 1/2"
Connections	NPT
Body Material	Ductile Iron
PMO Max. Operating Pressure	200 PSIG
TMO Max. Operating Temperature	650°F
PMA Max. Allowable Pressure	300 PSIG up to 450°F
TMA Max. Allowable Temperature	450°F @ 300 PSIG



TYPICAL APPLICATION

The **WLDE Series** high-capacity drainers meet the flow requirements that are typically found in heavy industrial process applications for air and other gases.

HOW IT WORKS

This liquid drainer has a float-operated valve that gives the trap a modulating flow characteristic. The amount of liquid flowing into the drainer is sensed by the float which positions the main valve to discharge the liquid at the same rate as it is received.

FEATURES

- Ductile iron body and cover
- In-line repairable
- All stainless steel internals for long service life
- High capacity liquid removal
- Rugged construction design for heavy industrial use

SAMPLE SPECIFICATION

The liquid drain trap shall be float operated with a ductile iron body and all stainless steel internals. The unit shall be in-line repairable and equipped with a FNPT threaded connection for the use of a balance line.

INSTALLATION

The installation should include isolation valves to facilitate maintenance and an in-line strainer. The trap must be level and upright for the float mechanism to operate. The 2" and 2-1/2" traps should not be supported by the piping alone. Trap must be sized and properly located in the system. Piping hook-up must include an equalizing line.

MAINTENANCE

Close isolation valves prior to any maintenance. All working components can be replaced with the drain trap remaining in the line. Repair kits include float, valve seat and disc and gaskets. For full maintenance details see Installation and Maintenance Manual.

MATERIALS

Body & Cover	Ductile Iron
Cover Screw	Carbon Steel, Gr 5
Cover Gasket	Garlock
Valve Discs	Stainless Steel, AISI 303
Main Valve Assembly Housing	Stainless Steel, AISI 304
Valve Assembly Gasket	Garlock
Ball Float	Stainless Steel, AISI 304
All other components	Stainless Steel

HOW TO ORDER

Refer to the capacity chart to determine which model is required to satisfy the condensate load.

LIQUID DRAINERS

WLDE Series

Float Type Liquid Drain Trap

Revised 9/2004

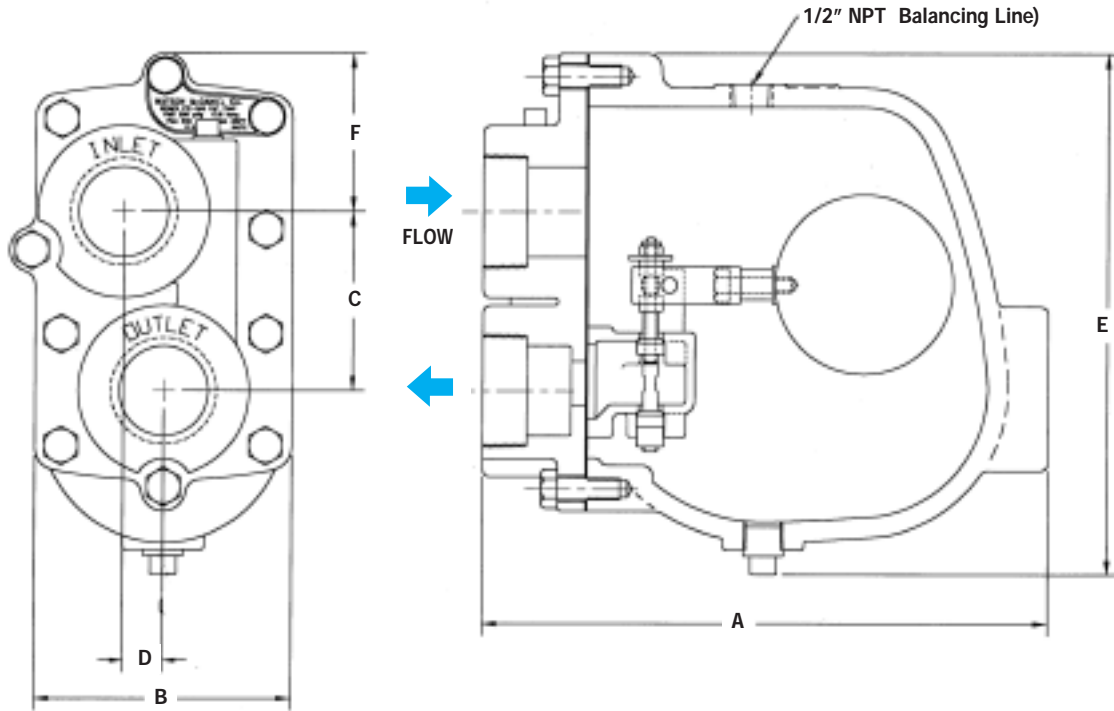

DIMENSIONS – inches / pounds								
Model	Size	A	B	C	D	E	F	Weight
WLDE-20	2"	12 ¹ / ₈	5 ¹¹ / ₁₆	4 ¹ / ₂	1/2	11 ¹ / ₈	3 ¹⁵ / ₁₆	44
WLDE-50	2"	16	8 ⁷ / ₁₆	7 ⁵ / ₁₆	1 ⁷ / ₁₆	15 ¹ / ₈	3 ¹ / ₈	91
WLDE-50	2 ¹ / ₂ "	15 ¹ / ₂	8 ⁷ / ₁₆	7 ⁵ / ₁₆	1 ⁷ / ₁₆	15 ¹ / ₈	3 ¹ / ₈	91
WLDE-125	2 ¹ / ₂ "	15 ¹ / ₂	8 ⁷ / ₁₆	7 ⁵ / ₁₆	1 ⁷ / ₁₆	15 ¹ / ₈	3 ¹ / ₈	92
WLDE-200	1 ¹ / ₂ "	9 ¹ / ₈	4 ⁵ / ₁₆	3	11/16	8 ¹³ / ₁₆	2 ¹ / ₈	23
WLDE-200	2"	12 ¹ / ₈	5 ¹¹ / ₁₆	4 ¹ / ₂	1/2	11 ¹ / ₈	3 ¹⁵ / ₁₆	50
WLDE-200	2 ¹ / ₂ "	15 ¹ / ₂	8-7/16	7 ⁵ / ₁₆	1 ⁷ / ₁₆	15 ¹ / ₈	3 ¹ / ₈	92

COLD WATER CAPACITIES – (lbs/hr)																	
Model	Size	Orifice	Differential Pressure (PSI)														
			1/4	1/2	1	2	5	10	15	20	40	50	75	100	125	150	200
WLDE-20	2"	.937"	3929	5556	7858	11113	17571	24849	30433	35141							
WLDE-50	2"	2.125"	12248	18153	25312	37751	62218	90068	106565	123365	161302	176522					
WLDE-50	2 ¹ / ₂ "	2.125"	19520	27605	39039	55209	87294	123452	151197	174588	246904	276047					
WLDE-125	2 ¹ / ₂ "	2.125"	19520	27605	39039	55209	87294	123452	151197	174588	246904	276047	338088	390390	436469		
WLDE-200	1 ¹ / ₂ "	.375"	1051	1486	2102	2973	4700	6647	8141	9401	13295	14864	18205	21021	23502	25745	29728
WLDE-200	2"	.75"	3403	4813	6807	9626	15220	21525	26363	30441	43050	48131	58949	68068	76102	83366	96263
WLDE-200	2 ¹ / ₂ "	1.5"	11111	15713	22222	31427	49690	70273	86066	99381	140546	157135	192450	222222	248452	272165	314269

LIQUID DRAINERS