

S20 Sensor Chamber, TP20 Temperature Sensor, CP10 Sensor and PT2 Plug-tail

- Purpose designed sensor chamber for in-line mounting
- Simple removal of sensors for cleaning
- Allows continuous temperature compensated measurement

Description

The Spirax Sarco S20 sensor chamber is fitted with conductivity and temperature sensors used to determine the conductivity of liquids. The use of a temperature sensor enables an accurate measurement to be made when the temperature varies, as in the case of condensate return monitoring systems.

The hexagonal in-line sensor chamber is screwed 1" NPT.

Adjacent radial female screwed connections are provided for:-

CP10 conductivity sensor (3/8" BSP).

TP20 temperature sensor (1/4" BSP).

An additional 1/4" BSP (1/4" NPT) connection is provided on the other side of the chamber for taking a sample if required.

Spirax Sarco can supply a sample cooler for cooling hot samples, or a blanking plug if the connection is not required.

The CP10 Sensor and PT2 Plug-tail are approved by Underwriters Laboratory as Listed accessories for use with Spirax Sarco Blowdown Controllers.

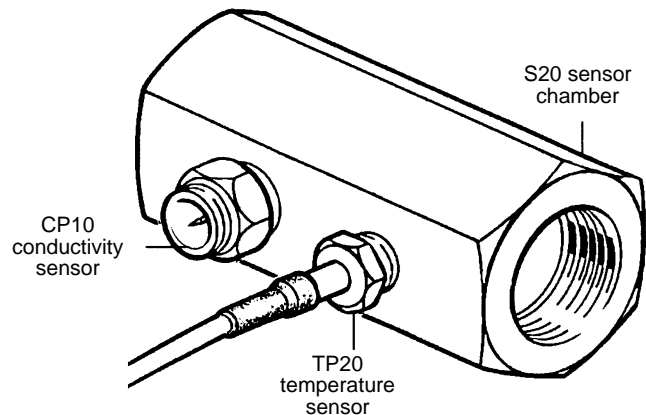

Limiting Conditions

S20 sensor chamber and TP20 Temperature sensor

Maximum pressure	160 psig (11 barg)
Maximum media temperature	302°F (150°C)

CP10 conductivity sensor

Maximum pressure	464 psig (32 barg)
Maximum media temperature	462°F (239°C)
Torque rating	44 lb./f (60 Nm)

PT2 Plug-tail

Cable temperature range	-67 to 248°F (-55 to 120°C)
Supplied cable length	50" (1.25m)
Maximum voltage	20Vdc, 14Vac
Maximum current	10mA

Installation

Fit the sensor chamber in a vertical or horizontal pipeline with suitable isolation valves to allow inspection/cleaning of the sensors. Reducers may be fitted if required. Flow can be in either direction. The sensors themselves must be horizontal.

The TP20 has a taper thread, and may be installed using PTFE sealing tape if required.

The CP10 sensor is provided with an S-type stainless steel gasket for sealing and does not require sealing tape.

Fit the sensors to the chamber and tighten.

Fit PT2 plug tail (or other Spirax Sarco plug tail) to the CP10 sensor and tighten.

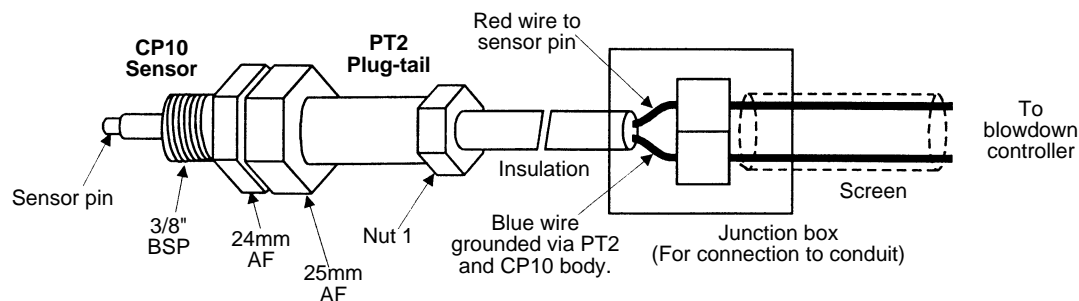

The supply to the Sensor and Plug-tail must be provided by a low voltage limited power source.

Spirax Sarco Blowdown controllers provide this type of supply.

Flexible metal conduit (M16) can be connected to the PT12 by removing the nut (1)

Local regulation may restrict the use of this product below the conditions quoted. Limiting conditions refer to standard connections only.

In the interests of development and improvement of the product, we reserve the right to change the specification.

TIS 9.403 US 01.01

S20 Sensor Chamber, TP20 Temperature Sensor, CP10 Sensor and PT2 Plug-tail

Maintenance

The equipment requires no specific maintenance other than periodic inspection and cleaning.

Materials

S20 sensor chamber

Stainless steel	ASTM 8582303	BS 970 303 S31
-----------------	--------------	----------------

PT2 Plug-tail

Body	Brass
Nuts (2off)	Brass
Insulator	Polyphenylene Sulphide Resin (glass filled)

CP10 conductivity sensor

Body	Stainless steel	BS 970 303 S31
Insulator	PEEK plastic	
Pin	Stainless steel	BS 970 303 S31

TP20 temperature sensor

Body and probe	Stainless steel 316	ASTM A269 Gr. 316
Cable insulation	PFA	

Approvals

UL	UL 3121-1
United States Standard	Process Control Equipment, Accessory E209497

ULC	C22.2 No. 1010.1
	Process Control Equipment, Accessory E209497

How to Specify

In line sensor chamber with conductivity and temperature sensors. CP10 Conductivity Sensor and PT2 Plug-tail to be approved by Underwriters Laboratory as Listed accessories for Blowdown Controllers."

How to Order

Spirax Sarco's S20 sensor chamber complete with CP10 sensor, PT2 plug tail, 1/4" BSP blanking plug, and TP 20 temperature sensor.

Dimensions (approximately) in inches

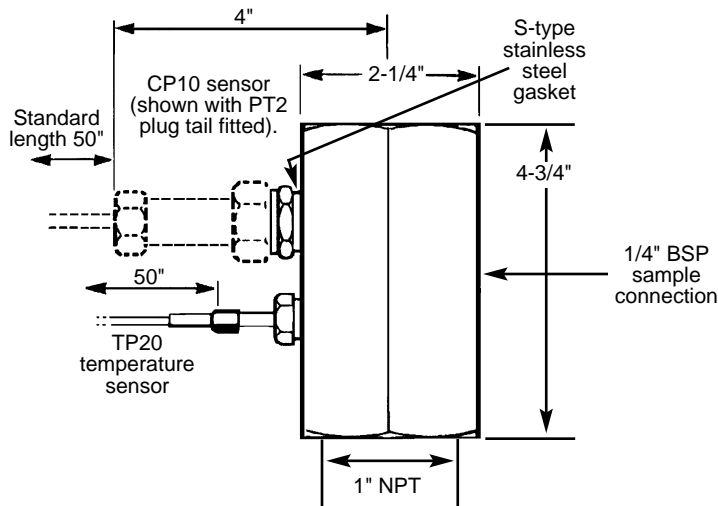

TIS 9.403 US 01.01