

# spirax/sarco®



## CP 30 Conductivity Probe

- Conductivity probe for use with blowdown controllers
- Suitable for use in steam boilers up to 464 psig. 462°F - (32 barg, 239°C)
- Easily cut to length
- All wetted parts in austenitic stainless steel/PTFE

### Description

The Spirax Sarco CP30 conductivity probe is used in conjunction with a controller to measure the conductivity or TDS of water, usually in a steam boiler for the purpose of monitoring and controlling blowdown. The probe may be installed in a Spirax Sarco probe elbow, a screwed flange, or directly in a boiler connection. The CP30 is supplied in four nominal tip lengths, and is cut to the exact length required prior to installation.

A DIN 43650 cable socket with 1/2" NPT conduit thread and four 18AWG wires are supplied with the unit.

### Limiting conditions

Maximum boiler pressure	464 psig	(32 barg)
Maximum temperature	462°F	(239°C)
Hydraulic ambient temperature	158°F	(70°C)
Minimum distance from boiler tubes	.8"	(20mm)
Minimum emersion depth (vertical installed probes)	4.0"	(100mm)
Cable socket protection rating	IP65	

\*Additional environmental protection is needed for outdoor installations.

### Installation

Probes with tip lengths up to 19.7" (500mm) can be installed vertically or horizontally. Vertical installation only is recommended for longer lengths. The probe must be installed in a position where it can sense the conductivity of the boiler water, away from the feed water inlet if possible. Full instructions on cutting the probe tip to length, wiring, and maintenance are given in the Installation and Maintenance Instructions supplied with each unit.

### Available Tip Lengths Inches and millimeters

11.8", 19.7", 39.4", 59.1"  
300, 500, 1000, 1500

### Weights (approximate) in lb (kg)

11.8" (300mm) tip version	1lb (0.47kg)
19.7" (500mm)	1lb (0.49kg)
39.4" (1000mm)	1.3lb (0.59kg)
59.1 (1500mm) tip version	1.5lb (0.68kg)

### Available Spares

Tip shroud and spring assembly, stock No. 4031280.

### How to Specify

Conductivity probe with all wetted parts in austenitic stainless steel and PTFE, 1/2" NPT, tip length 19.7" (500mm), and approved by Underwriters Laboratory as a Recognized Component.

### How to Order

Spirax Sarco UL CP30 (1/2" NPT) probe with 19.7" (500mm) tip.

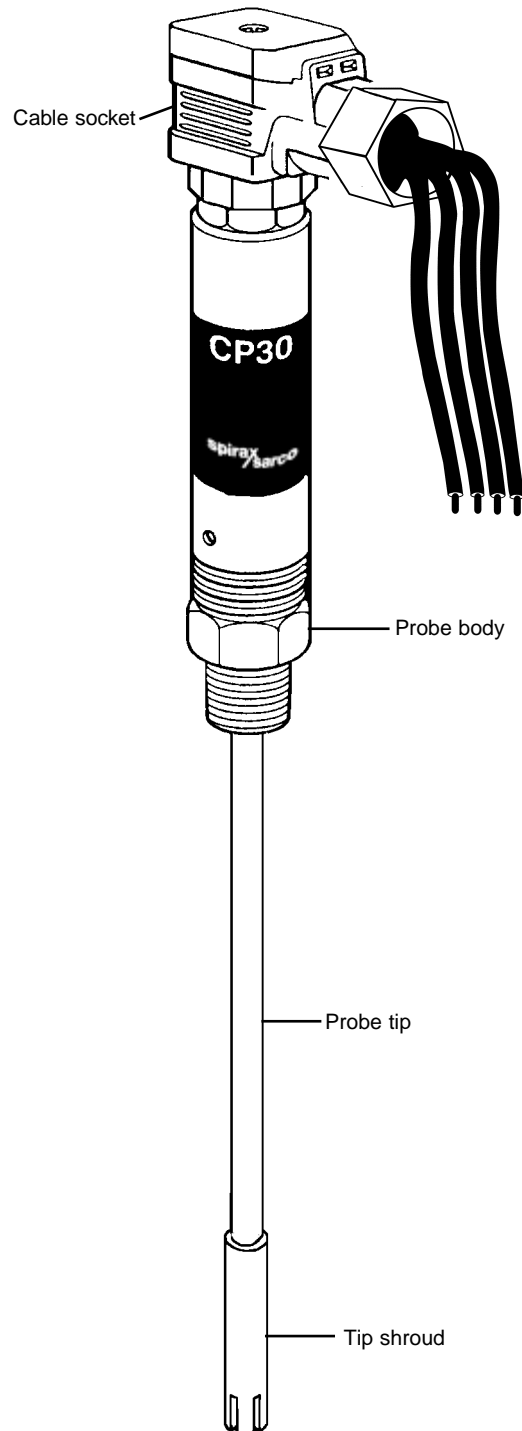

# CP 30 Conductivity Probe

**Dimensions** (approximate) in inches and millimeters

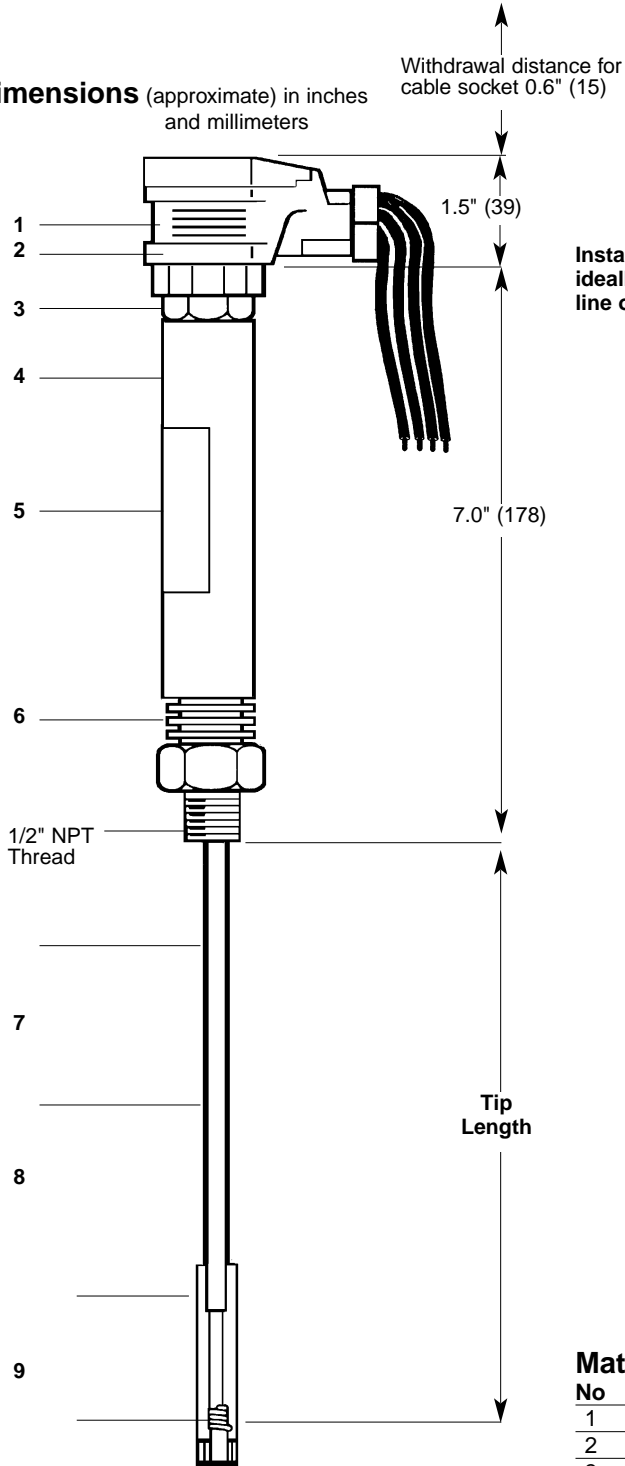

## Installation Examples

Installation on a probe elbow, ideally on the horizontal center line of the boiler.

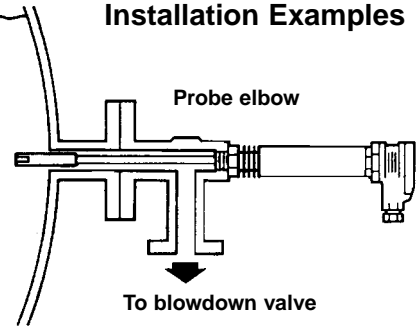

Installation on a boiler (screwed or flanged)

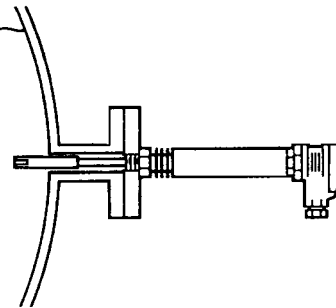

Vertical installation on a boiler standpipe

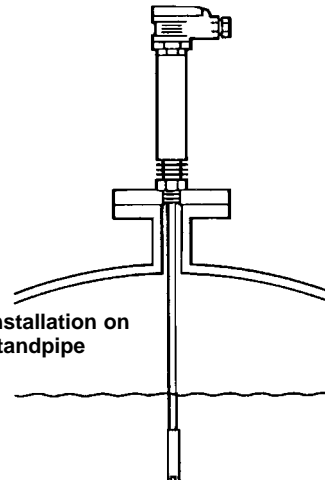

## Wiring

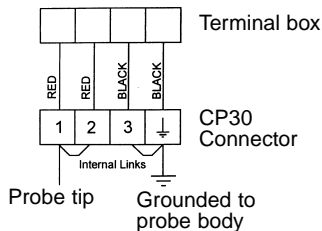

## Materials

No	Description	Material
1	Cable socket	Polyamide, glass filled
2	Flat gasket	Silicone rubber
3	Probe connector	Polyamide, glass filled
4	Cover assembly	Austenitic stainless steel
5	Nameplate	Aluminum foil
6	Body	Austenitic stainless steel Type 316Ti W/S No. 1.4571
7	Probe tip	Austenitic stainless steel ASTM A276 316L
8	Probe tip sleeve	PTFE
9	Tip shroud	PTFE
10	Spring	Austenitic stainless steel BS 2056 316 S42
11	Flying leads	Copper conductor, PVC insulation 18AWG CSA TEW 105oC, UL1015 105oC, 600V

## Approvals

UL	UL3121-1 Process Control
United States	Equipment, Accessory E209497
ULC	C22-2 No.1010-1 Process Control
Canadian Standard	Equipment, Accessory E209497

TIS 9.202 US 03.01