

## BCV 1 Solenoid Valve

- Normally closed operation
- For boiler blowdown duty
- Wide, non-critical voltage range

### Safety

Your attention is drawn to Safety Information Leaflet IM-GCM-10, and, in the UK, to IEE Regulations (BS 7671). Elsewhere, other regulations will normally apply.

### Description

The BCV 1 is a small bore, normally closed solenoid valve with a brass body and corrosion resistant internal components. It is primarily intended for low and medium pressure boiler blowdown applications.

Valves are supplied complete with a mains connector and is suitable for 3 x 1mm<sup>2</sup> (18 AWG) cable.

### Limiting Conditions

	BCV1	BCV1 (UL/CSA)
Maximum boiler or steam pressure	203 psig (14 barg)	130psig (9 barg)
	Intermittent operation	
Media	-40 to 392°F	-40 to 356°F
Temperature	(-40 to 200°C)	(-40 to 180°C)
Media	Water and flash steam	Water and flash stem
Maximum ambient temperature	130°F (55°C)	130°F (55°C)

### Response Times (ms)

Opening	10 - 20
Closing	20 - 30

### Available Sizes and Connections

1/2" screwed NPT - 120 V version

1/2" screwed NPT - 120 V version (UL/CSA Listed BCV1)

### Electrical Data

Voltage range	108 V to 132 V
Frequency	50 — 60 HZ
Maximum power consumption	40 VA (inrush) 16 VA/12W (hold)
Protection Rating	IP65 (Nema 4)

### Dimensions inches and (mm)

A	B	C	D	E	Weight
1.6"	4.3"	2.9"	3.7"	2.9"	1.6 lb
(40)	(110)	(74.5)	(94.5)	(73)	(0.73 kg)

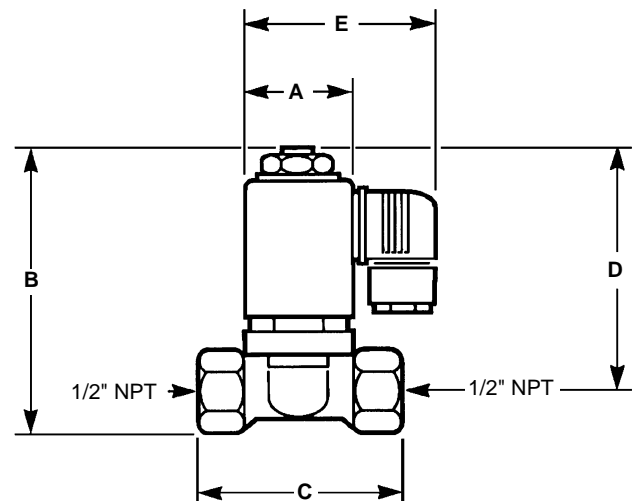
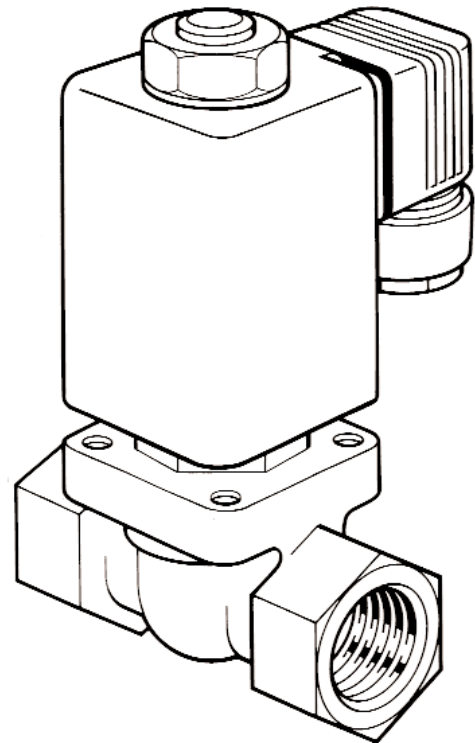

### Materials

Part	Material
Body	Brass
Seal	PTFE
Internal components	Stainless Steel

# BCV 1 Solenoid Valve

## Capacities

Orifice diameter 1/8"

$C_v = 0.29$

For conversion  $K_v (UK) = \frac{C_v}{1.17}$

Boiler Pressure psig

Capacity lb/h

14.5	385
29	550
58	770
87	847
116	979
145	1089
203	1298

## Installation

We recommend that a strainer is fitted upstream of the valve. Fit the valve with the flow in the direction of the arrow, in a horizontal pipeline with the solenoid vertically above the valve.

Do not overtighten screws, nuts, or pipework as this could damage the valve body.

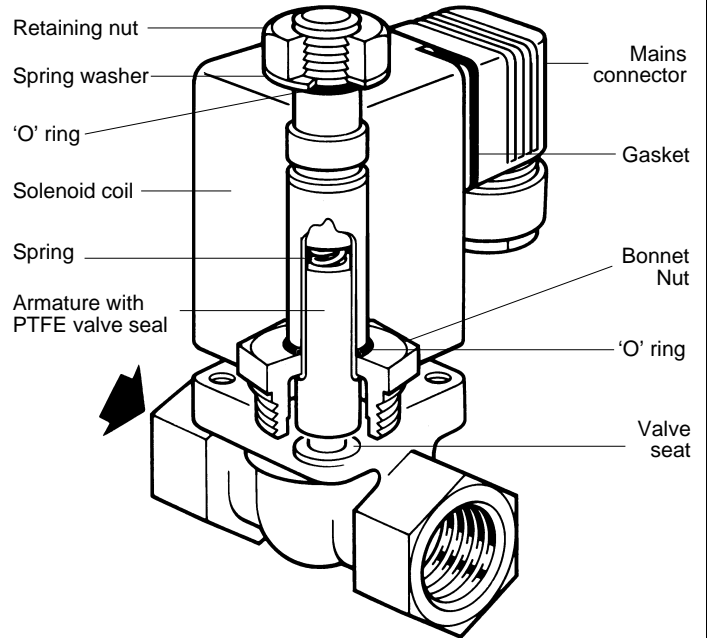
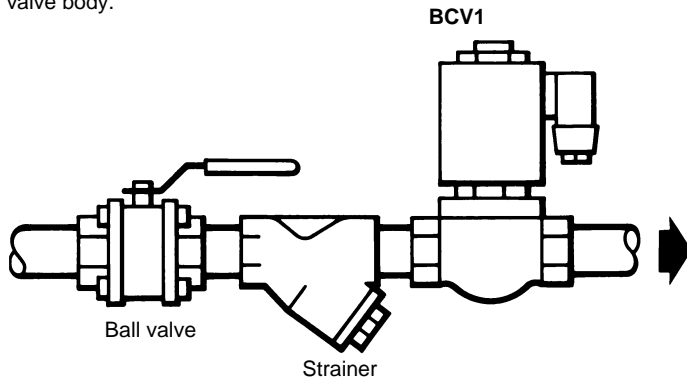

## Wiring

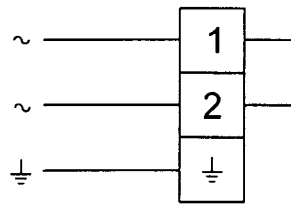

Caution: Do not apply power to the coil unless it is fitted to the valve.

The rated voltage is printed on the nameplate. For ease of installation the solenoid coil can be moved through 360° by

slackening the solenoid nut. The cable socket may be fitted horizontally or vertically by removing the central plastic screw and turning the connector through 90°. Ensure the cable socket gasket is slightly compressed on refitting.

## Maintenance

(If it becomes necessary to dismantle the valve, proceed as follows:

1. Disconnect the mains supply.
2. Remove retaining nut and washer and withdraw solenoid coil.
3. Remove the bonnet nut and withdraw armature and spring.
4. Clean the valve and examine the seating surfaces for damage.
5. Replace the spring and armature if required.
6. Reassemble valve in the reverse order of dismantling.

## Approvals

UL	UL 429
United States Standard	Electrically Operated Valve, Safety Valve (MH10752)
ULC	C22.2 139
Canadian Standard	Electrically Operated Valve, Safety Valve (157357)

## Available Spares

Armature and spring set (kit).	Stock No. 4034080
Coil 110 V / 120V	Stock No. 4034082

## How to specify

1 Spirax Sarco type BCV1 blowdown valve, screwed 1/2" NPT, 120V, 60 Hz and approved by Underwriters Laboratory and CSA as a Listed product.

Wiring should be carried out using suitable 3 core, 18AWG (1mm<sup>2</sup>) high temperature (90°C minimum) cable.

Ensure that sufficient cable length is provided to allow removal of the cable socket and to ensure that no strain is placed on the unit. The cable socket for the standard valve is fitted with a PG16 cable gland. The cable socket (Type H) for the UL/CSA Listed valve is provided with a female 1/2" NPT thread for connection to a length of flexible metal conduit. To retain the integrity of the approvals the valve must be installed with the H type cable socket.

**Caution:** Care must be taken to ensure that any condensation which might buildup in the conduit network, is prevented from accumulating in the valve cable socket.

To unplug the cable socket, remove the central screw.

To gain access to the connector block within the cable socket for the standard valve, remove the plastic internal central screw and withdraw the connector block. For the UL/CSA Listed valve, simply remove the lid.

The connector block may be rotated in 90° steps to facilitate wiring. Electrical connection must be made before the socket and the gasket is fitted to the valve. Flat terminal = Ground connection  
Note: - To provide environmental protection the valve is supplied with a gasket between the cable socket and the valve connector. To maintain environmental integrity, ensure gasket is always present when reconnecting cable socket and contact surfaces are undamaged and are clean.

The tightening torque for the cable plug central retaining screw is 1 Nm.

TIS 9.201 US 02.01