

spirax/sarco®

LC 1000 Level Controller

DESCRIPTION

The Spirax Sarco LC1000 controller is a two-channel, dual voltage level controller for use with conductivity probes in conductive liquids. The controller is suitable for use with virtually all qualities of industrial waters from condensate or boiler water to salt solutions, and can be used in water with an electrical conductivity as low as 10 micro Siemens/cm.

The LC 1000 has two sensitivity levels and a wave filter function which allows it to give a precise response under the very different conductivity and turbulence conditions found in tanks and high output boilers.

Both functions are switch-selectable.

The controller is set up before installation to suit the mains supply voltage and to provide the required level control and level alarm functions.

Configuration labels are provided for the controller front panel and enclosure chassis plate.

APPLICATIONS

The LC 1000 controller can provide the following functions, which are selected by an 8-way switch on the printed circuit board:-

- High and low alarm
- Two low alarms
- Two high alarms
- Pumping in/low alarm
- Pumping out/low alarm
- Pumping in/high alarm
- Pumping out/high alarm

Full commissioning instructions are given in the Installation and Maintenance Instructions supplied with the unit.

LIMITING CONDITIONS

Enclosure rating	IP40
Maximum ambient temperature	131°F (55°C)
Maximum cable length (controller/probe)	100 ft.

INSTALLATION

WARNING:-isolate the mains supply before unplugging the controller as live terminals will be exposed in the controller base.

The controller should be installed in an enclosure or control panel to provide environmental protection. The controller may be mounted on a 'top hat' DIN rail using the mounting clip provided or the clip may be removed and the controller base screwed direct to a chassis plate. Screened cable is required for the probe. A suitable cable is Belden 83654 (4-core). The same type of cable may also be used for the mains wiring. Individual wiring diagrams and selection switch settings are shown in the Installation and Maintenance Instructions.

TECHNICAL DATA

Mains supply voltage	
230V setting	198V - 264V
115V setting	99V - 121V
Frequency	50 - 60Hz
Maximum power consumption	6VA

MATERIALS

Case	Polystyrene
Baseplate	ABS (Reinforced)

HOW TO SPECIFY

1- Spirax Sarco LC 1000 controller

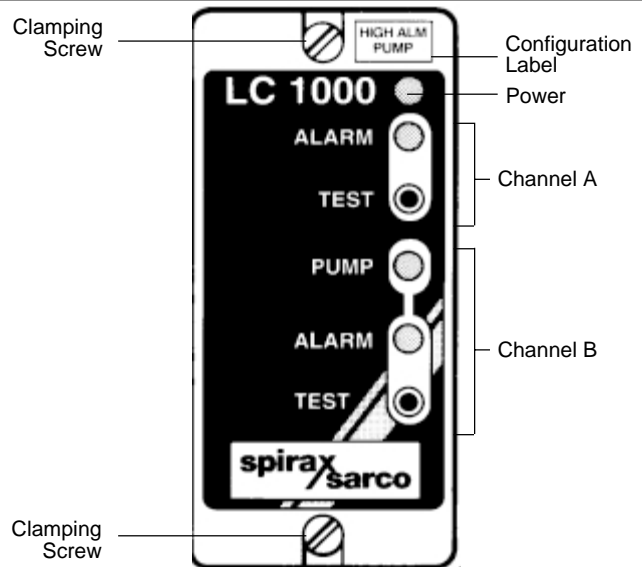

GENERAL WIRING DIAGRAM

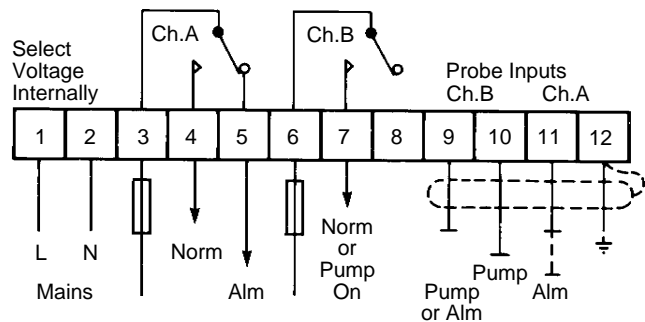

DIMENSIONS (approximate) in inches

