

spirax/sarco®



LC 2500 Level Controller

- On/off controller with adjustable level settings
- Switching levels altered without de-commissioning boiler
- Two channels for pump control and/or alarm
- Capacitance probe or 4-20mA input

Description

The LC 2500 is a two channel, dual voltage level controller with adjustable switching levels, and is normally used in conjunction with a capacitance type level probe.

Either of the channels, (designated A and B), can be set to provide a high or low alarm, and channel B can also provide an adjustable pump on/off control.

Alternatively, the controller can power and accept a 4-20mA signal from a pressure or differential pressure transmitter.

Several controllers may be linked to provide additional alarms.

The LC 2500 has an 'out of range' alarm, which operates if the probe or wiring is damaged, or has been incorrectly wired, enabling prompt action to be taken to rectify any potentially dangerous situation.

The controller has a wave filter function which acts as a damper, preventing over-frequent relay operation in turbulent conditions.

Voltage and functions are set on installation using internal switches, and control and alarm levels are adjusted using potentiometers on the front panel.

Configuration labels are provided for the controller front panel and enclosure chassis plate, and indicate the mode selected.

Applications

The LC 2500 controller can provide the following functions, which are selected by an 8-way switch on the printed circuit board.

High and low alarm	Pumping in/low alarm
Two low alarms	Pumping out/low alarm
Two high alarms	Pumping in/high alarm
	Pumping out/high alarm

Full commissioning information is given in the Installation and Maintenance Instructions supplied with the unit.

Limiting conditions

Enclosure rating	IP 40
Maximum ambient temperature	130°F (55°C)
Maximum cable length (controller/probe)	300ft (100m)

Technical data

Mains supply voltage	
230V setting	198V-264Vac
115V setting	99V-121Vac
Frequency	50-60Hz
Fuse type	20mm, 100mA
	antisurge (UL Recognized)
Maximum power consumption	6VA

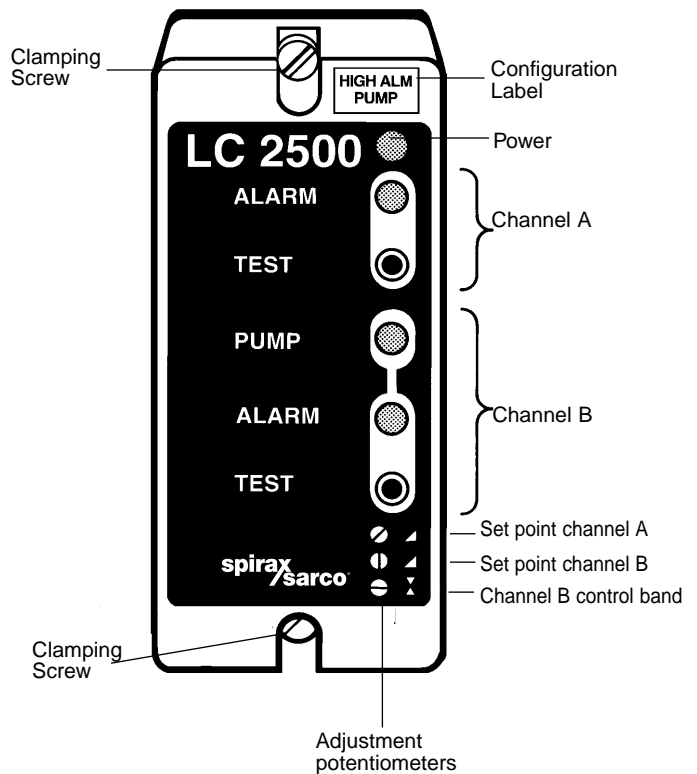

Local regulation may restrict the use of this product below the conditions quoted. Limiting conditions refer to standard connections only. In the interests of development and improvement of the product, we reserve the right to change the specification.

LC 2500 Level Controller

Installation

WARNING Isolate the mains supply before unplugging the controller as live terminals at mains voltage will be exposed in the controller base.

The controller must be installed in a suitable industrial control panel or fireproof enclosure to provide environmental protection (pollution degree 2).

The controller may be mounted on a "top hat" DIN rail using the mounting clip provided or the clip may be removed and the controller base screwed directly to a chassis plate.

Only copper cable is to be used. Screened cable is required for the probe. A suitable cable is Pirolli FP2000 or Delta Crompton Firetuf OHLS, 3 core 1mm².

The same type of cable may also be used for the mains wiring. Full wiring diagrams, selection switch settings, and adjustments are given in the installation and Maintenance instructions supplied with each controller.

Materials

Enclosure base & connector	Noryl SE1 GFN2
Enclosure cover & intermediate plate	R-ABS 90.00

Relay Rating

Lamp or Resistive	3A
Tungsten Filament	1A
AC Motor @ 240V	1/4HP (2.9A)
AC Motor @ 120V	1/10HP (3.0A)
Pilot Duty (control circuits & coils)	C300 (2.5A)

Field Wiring/Terminal Details

Max Wire Gauge	2x16 AWG (1.5mm ²)
Conductor material	Copper
Terminal Torque rating	9 lb/in

Approvals

UL	UL 508
United States Standard	Industrial Control Equipment E203559
cUL	C22.2 Number 14-M91
CSA Canadian Standard	Industrial Control Equipment E203559

How to specify

2 channel level controller with adjustable switching levels, wave filter, and out of range alarm.

How to order

Spirax Sarco LC2500 UL Level Controller.

General wiring diagram

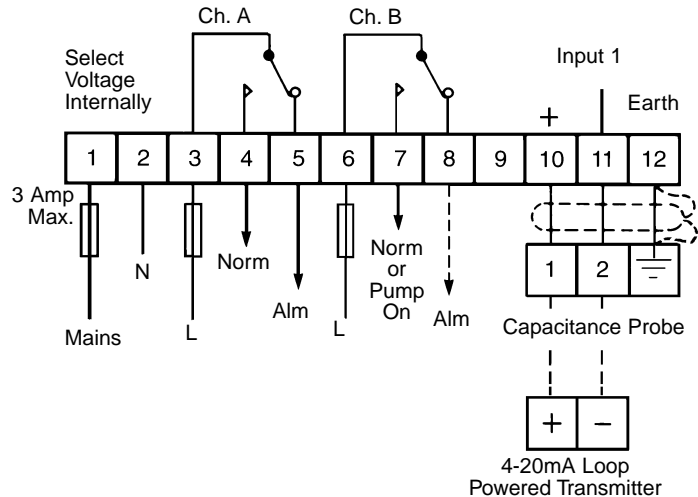

Dimensions (approximate) in inches and millimetres

