

spirax/sarco®

Orifice Plate Flowmeters M410 Orifice Plate and Carrier Assembly

DESCRIPTION

The M410 Orifice Plate and Carrier assembly is a primary flow element consisting of a tab handled square edged orifice plate and optional carrier. The orifice plate is designed and manufactured to meet the requirements of ASME-MFC-3M in all respects and is suitable for the measurement of the rate of flow of most liquids, gases and steam. The tab handled orifice plate can be used:

- a: on its own fitted between flanges with pressure tapings in the users pipework or flanges.
or
- b: fitted into a carrier with integral flange tapings designed to fit between customer flanges.

LIMITING CONDITIONS

The pressure and temperature limitations of both the tab handled plate and the carrier assembly are the same as the specified flange ratings.

PERFORMANCE

The performance of an orifice plate metering system can be greatly influenced by installation variables, so the figures given below are for guidance only:

- Accuracy: typically +/- 3% of actual flow.
(equivalent to +/- 1.5% full scale deflection at 50% of rated maximum flow).
- Repeatability: typically +/- 0.3%.
- Turndown: typically 4:1.

PIPE SIZES AVAILABLE

Tab handled plates with or without carriers are available to suit the following pipe sizes:
1", 1-1/2", 2", 2-1/2", 3", 4", 5", 6", 8", 10", 12", 14", 16", 18", 20", 24"

CONNECTIONS

Tab handled plates and carriers are available to suit the following flange specifications:
ANSI B 16.5 class 150, 300, 600.

CONSTRUCTION MATERIALS

Tab handled orifice plate	Stainless Steel Grade 316
Carrier	passivated zinc plated carbon steel
Gaskets	exfoliated graphite

PRESSURE TAPPINGS

When the tab handled orifice plates are used without the optional carrier, it is the responsibility of the user to provide appropriate pressure tapings in either the flanges or upstream and downstream pipework in line with ASME-MFC-3M.

The optional carrier assembly incorporates upstream and downstream pressure tapings threaded 1/2" NPT. These tapings are 1 inch either side of the orifice plate face in line with the requirements of ASME-MFC-3M

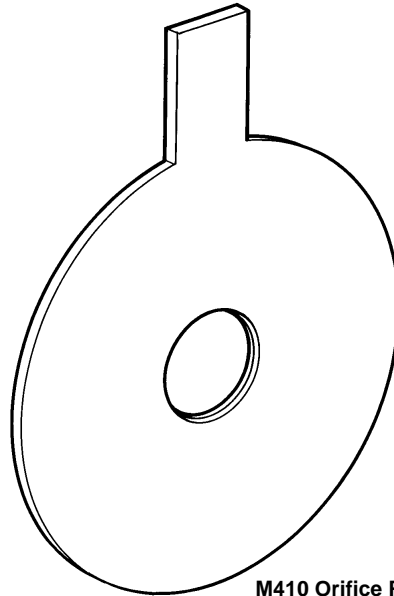

M410 Orifice Plate

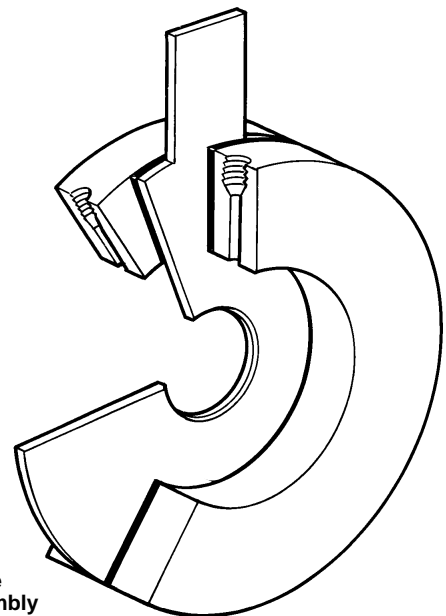

M410 Orifice Plate
and Carrier Assembly

Orifice Plate Flowmeters

M410 Orifice Plate and Carrier Assembly

ASSOCIATED EQUIPMENT

M240G series steam flow computer	TIS 8.300
M250G series gas flow computer	TIS 8.301
M700 display unit	TIS 8.302
M610 DP transmitter assembly	TIS 8.400
F50C isolation valve	TIS 8.401
EL2270 temperature sensor	TIS 8.402
EL2271 temperature sensor & transmitter assy.	TIS 8.402
EL2810 temperature transmitter	TIS 8.402
EL2600 pressure transmitter	TIS 8.403
M640 steam mass flow transmitter assembly	TIS 8.404

For a general description of Spirax Sarco orifice plate flowmetering systems, see TIS 8.202 (density compensated system) and TIS 8.201 (non density compensated system).

INSTALLATION

It is important that all details of the installation conform to ASME-MFC-3M. Of special note, is the long, straight lengths of pipe that must be present upstream of the orifice plate. As an approximate guide, 20 to 30 pipe diameters upstream and 5 downstream should be adequate but it is recommended that reference is made to the relevant standard. A summary of the basic requirements is included with the M410 equipment.

MAINTENANCE

A visual inspection of the orifice plate should be made at regular intervals to check for dirt buildup, damage or a loss of sharpness of the upstream edge of the plate. Replacement orifice plates and gaskets are available from Spirax Sarco.

HOW TO SPECIFY

Spirax Sarco M410 Orifice plate primary element with/without optional carrier assembly conforming to ASME-MFC-3M.

HOW TO ORDER

1- Spirax Sarco M410 orifice plate and carrier assembly.

Important note: In order that a correctly sized orifice plate can be supplied, it is essential that full details of the installation and estimated flow rates are supplied to Spirax Sarco. This is best done using an orifice plate customer data sheet (TIS 8.203) info available from Spirax Sarco.

NOTES:

- 1: Dimension C is 1 inch for all sizes.
- 2: For line sizes 1" to 10", orifice plate thickness T is 3mm, 12" and above, T is 6mm.
- 3: Gaskets are 1.6 mm thick.
- 4: For line sizes up to 14", carrier assembly thickness B is 82mm, 16" and above, B is 85mm.
- 5: Maximum weights shown are based on ANSI 600 flanges.

DIMENSIONS (approximate) in inches

Inches	ANSI 150 A	ANSI 300 A	ANSI 600 A	Maximum Weight Lb
1	2.63	2.87	2.87	5.20
1-1/2	3.37	3.75	3.75	8.20
2	4.12	4.37	4.37	10.82
2-1/2	4.87	5.13	5.13	13.69
3	5.37	5.88	5.88	17.44
4	6.87	7.13	7.63	30.31
5	7.75	8.5	9.5	46.25
6	8.75	9.88	10.5	51.83
8	11	12.13	12.62	68.89
10	13.37	14.25	15.75	105.71
12	16.13	16.62	18	129.50
14	17.75	19.12	19.37	132.72
16	22.61	21.25	22.25	189.58
18	21.62	23.5	24.12	208.07
20	23.87	25.75	26.87	259.46
24	28.25	30.5	31.13	322.69

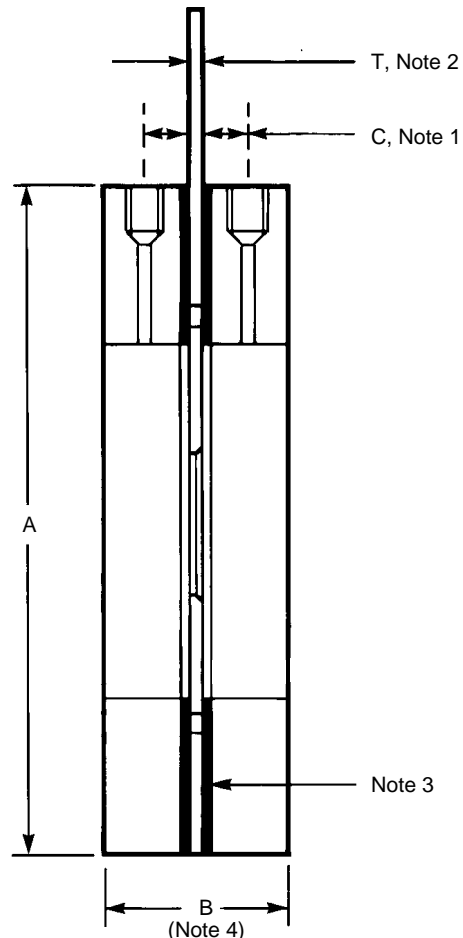

TIS 8.200 US 09.99