

spirax sarco®

PN5700 Series Fail Closed Pneumatic Actuators for 6" and 8" K Series Valves

Description

A range of linear actuators for matching the requirements of 6" to 8" valves at various differential pressures. The actuators are fitted with a mechanical stroke indicator and incorporate a semi-rolling diaphragm to produce good linearity over the operating stroke.

These actuators are designed to operate with two port K series valves.

Actuator type	Valve types	Valve sizes
50 mm travel	K series	6" and 8"
30 mm travel	K series	6" and 8"

Available types

Spring extend spindle, multi-spring pillars mounted actuators PN5700 series.

Spring ranges

Actuator types	Spring range	Travel
PN5750	3 to 15 psi (6 to 18 psi)	50 mm
PN5756	15 to 45 psi	50 mm
PN5757	12 to 36 psi	50 mm

Technical data

Temperature range	-4°F to +212°F (-20°C to +100°C)
Maximum operating pressure	65 psig (4.5 barg)
Air supply connection	1/4" NPT

Dimensions/weights (approximate) in inches and lbs (mm and kg)

Actuator	D	E	Weight
PN5700 series	18.6(465)	20.2(505)	110(50)

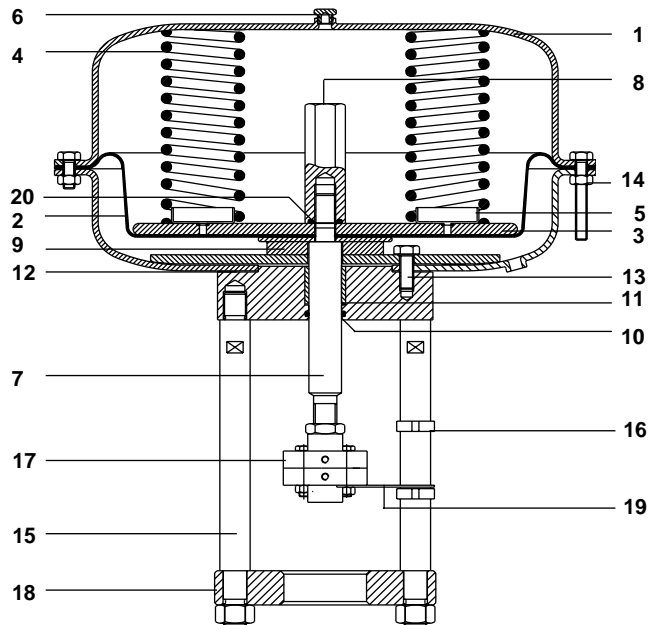
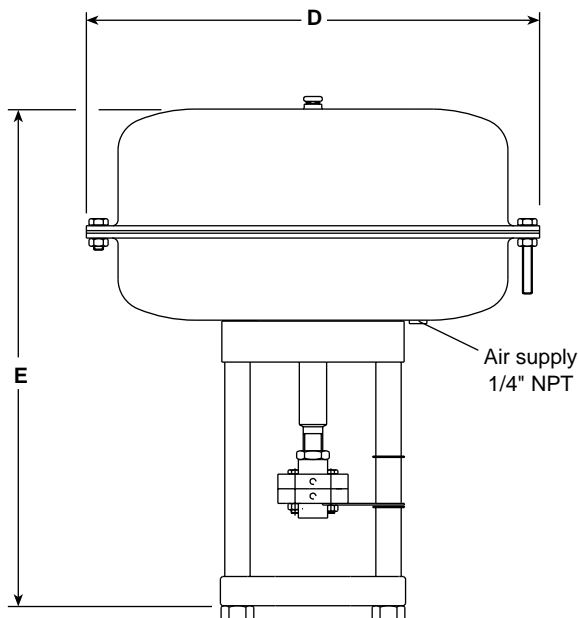

Materials

No	Part	Material
1	Diaphragm housing	Steel
2	Diaphragm	Reinforced nitrile rubber
3	Diaphragm plate	Steel
4	Spring	Spring steel
5	Spring guide	Zinc plated steel
6	Vent plug	Nickel plated brass
7	Spindle	Stainless steel
8	Lock-nut / spacer	Stainless steel
9	Clamp plate	Zinc plated steel
10	Spindle 'O' ring	Nitrile rubber
11	Guide bush	Bronze
12	Gasket	Non asbestos fibre
13	Fixing screws	Steel
14	Housing bolts and nuts	Steel
15	Pillar	Zinc plated steel
16	Travel indicator	Stainless steel
17	Linkage set	Zinc plated steel
18	Mounting plate	Zinc plated steel
19	Anti-rotation plate	Zinc plated steel
20	Sealing 'O' ring	Nitrile rubber
21	Pillar nut	Zinc plated steel

Differential pressures for PN5700 actuators

Valve size				6"				8"			
Travel mm				30				30			
Valve seat size				Full Cvs	Reduced Cv			Full Cvs	Reduced Cv		
					No. 1	No. 2	No. 3		No. 1	No. 2	No. 3
Actuator	Spring range psi	Minimum air pressure psig	Positioner required	Maximum closing pressure (psi) (see note reference differential pressures)							
	PN5750	3 - 15	20	Optional	6.5	11.5	-	-	1.5	6.5	11.5
6 - 18		25	Optional	25	40	-	-	13.5	25	40	-
PN5756	15 - 45	50	Yes	96	140	-	-	50	96	140	-
	12 - 36*	50	Yes	-	-	330	525	-	-	-	330

*Standard 50 mm travel actuator will provide 30 mm travel across spring range shown.

Note: The valves shown are valid for both standard and high temperature packing. The above closing pressures are based on zero air in actuator.

Installation

Actuators should be mounted on the valve with the stem in a vertical position. Installation and Maintenance Instructions are supplied with the product.

How to order

Example: 1 off PN5750 pneumatic actuator.

Spare parts

The spare parts available are indicated by capital letters. The other parts are not supplied as spares.

Available spares

Stem seal kit	A
Diaphragm kit	B
Spring kit	C
Linkage kit (lock-nut, top adaptor, bottom adaptor, bolts and nuts)	D, E, F, G

How to order spares

Always order spares by using the description in the column headed 'Available spares' and stating the actuator type.

Example: Diaphragm kit for PN5750 pneumatic actuator.

