

spirax/sarco®

Cast Steel Valves 6" and 8" KEA43

Description

Two port cast steel single seat globe valves conforming to ANSI/ASTM standards in sizes 6" and 8" (DN150 and DN 200) available with flanged connections. When used in conjunction with a pneumatic or electric linear actuator they provide characterized modulating or on/off flow control. For close control with pneumatic actuators a valve positioner should additionally be used.

Compatible actuators and positioners

| | |
|--------------------|--|
| Electric | EL5600 series |
| Pneumatic | PN5700, PN6700, PN7000 and PN8000 series |
| Positioners | PP5 (pneumatic) |
| | EP5 and ISP5 (electropneumatic) |
| | SP2 (smart electropneumatic) |

Refer to the relevant Technical Information Sheet for further details.

Sizes and pipe connections

KEA43 6" and 8" (DN150 and 200) flanged ANSI 150 and ANSI 300.

Options

| | |
|------------------|---|
| Trim soft | Equal %, linear, reduced Cv, fast opening (on/off) seal, hard faced, low noise and anti-cavitation. |
| Stem seal | PTFE chevrons and graphite packing. |

Refer to TI-P305-04 for further details.

Technical data

| | | |
|---------------------|-----------------------------|-------------------------------|
| Plug design | 6" and 8" (DN150 and DN200) | Vee port |
| Leakage | Metal-to-metal seat | ANSI/FCI 70/2 Class IV |
| | PTFE soft seal | ANSI/FCI 70/2 Class VI |
| Flow characteristic | KEA valves | Equal percentage (modulating) |
| | KLA valves | Linear (modulating) |
| | KFA valves | Fast opening (on/off) |
| Rangeability | | 50 to 1 |
| Travel | 6" and 8" (DN150 and DN200) | 2" (50 mm) |

Limiting conditions

| | | |
|---|-----------------------|-----------------------|
| Body design conditions | ANSI 150 and ANSI 300 | |
| Maximum design temperature | PTFE chevron seals | 482°F (250°C) |
| | Graphite packed seals | 800°F (426°C) |
| Minimum design temperature | 14°F (-10°C) | |
| Design for a maximum cold hydraulic test pressure of: | ANSI 150 | 450 psig (32.0 barg) |
| | ANSI 300 | 1125 psig (77.6 barg) |
| Maximum differential pressures | see actuator TI | |

Operating range

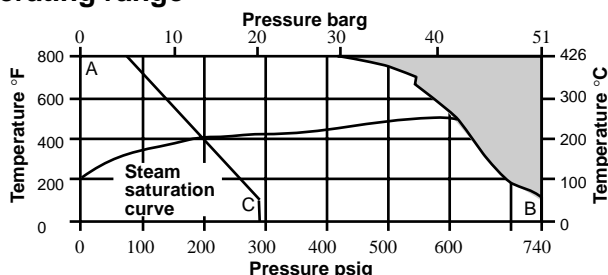

The product must not be used in this region
 A - B Flanged ANSI 300 A - C Flanged ANSI 150

Local regulations may restrict the use of this product below the conditions quoted. Limiting conditions refer to standard connections only.
 In the interests of development and improvement of the product, we reserve the right to change the specification.

KEA43 6" and 8"

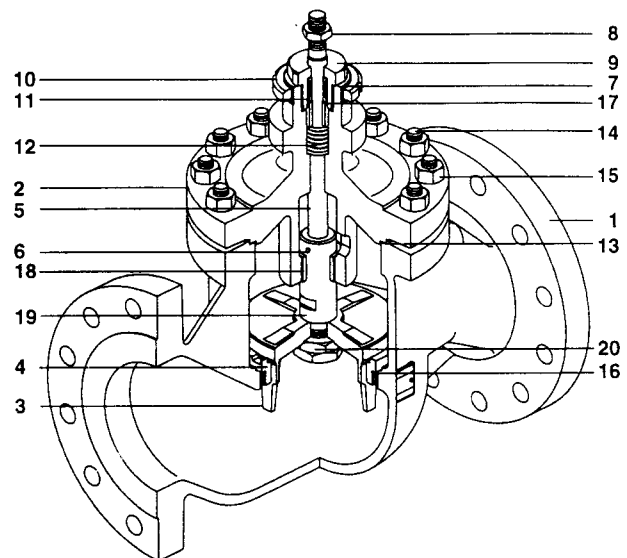

Materials

| No | Part | Material | |
|----|------------------|-------------------------------|--------------------|
| 1 | Body | Cast Steel | ASTM A216 WCB |
| 2 | Bonnet | Cast Steel | ASTM A216 WCB |
| 3 | Valve plug | Stainless steel | ASTM A276 Gr. 431 |
| 4 | Valve seat | Stainless steel | ASTM A276 Gr. 431 |
| 5 | Valve stem | Stainless steel | ASTM A276 Gr. 431 |
| 6 | Pin | Stainless steel | AISI 302 |
| 7 | Gland nut gasket | Semi-rigid graphite laminated | |
| 8 | Lock-nut | Stainless steel | |
| 9 | Gland nut | Stainless steel | ASTM A276 Gr. 431 |
| 10 | Mounting nut | Mild steel zinc plated | |
| 11 | Gland seals | PTFE chevrons | |
| 12 | Gland spring | Stainless steel | |
| 13 | Bonnet gasket | Semi-rigid graphite laminated | |
| 14 | Bonnet studs | Steel | ASTM A193 B7 |
| 15 | Bonnet nuts | Steel | ASTM A194 2H |
| | | 6" (DN150) | 5/8" UNC |
| | | 8" (DN200) | 3/4" UNC |
| 16 | Seat gasket | Semi-rigid graphite laminated | |
| 17 | Guide bush | Glass reinforced PTFE | |
| 18 | Bonnet guide | Stainless Steel | AISI 440B Hardened |
| 19 | Valve post | Stainless steel | ASTM A276 Gr. 431 |
| 20 | Plug lock-nut | Stainless steel | |

Cv values

| Size | 6" (DN150) | 8" (DN200) |
|-------------------------|------------|------------|
| Equal % and linear trim | 280 | 492 |
| On/Off trim | 280 | 500 |

These reductions in Cv are available for equal percentage and linear trims, for details see TI-P305-04 KEA valve options.

For conversion $Cv (UK) = Cv \times 0.833$ $Kvs = Cv (US) \times 0.855$

Dimensions/weights (approximate) in inches and lbs

| Valve size | A | B (ANSI 150) | B (ANSI 300) | Weight |
|------------|-----|-----------------|-----------------|--------|
| 6" (DN150) | 283 | 451 | 473 | 165 |
| 8" (DN200) | 330 | 543 | 568 | 249 |

Installation

The valve should be installed in a horizontal pipeline with the direction of flow as indicated by the arrow on the valve body.

If necessary the actuator should be commissioned in accordance with the Installation and Maintenance Instructions supplied with the valve.

How to order

Example: 1 off 6" KEA43 Cv 280 control valve flanged ANSI 150

Spare parts

See TI-P305-05

KEA43 6" and 8"

